

# Promoting reading in the first language



Materials for heritage language teaching

**Didactic suggestions**

**2**

# Promoting reading in the first language

Maria Riss

Elisa Aeschimann-Ferreira  
and Raquel Rocha

Materials for heritage language teaching

**Didactic suggestions**

**2**

---

Series "Materials for heritage language teaching"  
(HLT; in Switzerland HSK: Instruction in native language and culture); Didactic suggestions 2.

Published by the Center for IPE (International Projects in Education) Zurich University of Teacher Education.



---

Project leader/editor: Basil Schader

---

Authors: Maria Riss, lecturer and project leader at the Center for Reading, Department of Teacher Education, Northwest Switzerland University of Applied Sciences; author of teaching materials in the area of reading promotion.

---

Editorial support for HLT: Elisa Aeschmann-Ferreira and Raquel Rocha

---

Test-teaching trials: Nexhat Maloku, Zürich (HSK Albanian)  
Hüsniye Göktaş, Zürich (HSK Turkish)  
Dragana Dimitrijević and Gordana Nikolić, Zürich (HSK Serbian)  
Elisa Aeschmann-Ferreira and Raquel Rocha (HSK Portuguese)  
Hazir Mehmeti, Vienna  
Rifat Hamiti, Düsseldorf

---

Illustrations, overall visual concept and realization: Barbara Müller, Erlenbach

---

Translator: Alfred Keller, Tamarac

---

Printing:

---

The series "Materials for heritage language teaching" was made possible with the support of the Swiss Federal Office of Culture (BAK).



Schweizerische Eidgenossenschaft  
Confédération suisse  
Confederazione Svizzera  
Confederaziun svizra

Eidgenössisches Departement des Innern EDI  
**Bundesamt für Kultur BAK**

---

This project was partially financed with the support of the European Commission.  
The responsibility for the content of this publication rests solely with the authors: the Commission has no responsibility for the further use of the information contained herein.



Lifelong  
Learning  
Programme

---

# Table of contents

<b>Preface to the series “Materials for heritage language teaching”</b>	7
---	---

---

## **Introduction**

<b>1</b> Reading in the heritage language: possibilities and challenges	8
<b>2</b> Goals and structure of this brochure	10
<b>3</b> Key aspects of current reading didactics	10
<b>4</b> Additional aspects specifically related to reading in the heritage language education classroom	13

---

## **Part I: reading promotion**

### Meeting books and texts

<b>1</b> Reading out loud as a ritual	20
<b>2</b> Establishing a small library in the first language	21
<b>3</b> Checking out books at institutions like “Bibliomedia”	22
<b>4</b> A library visit	22
<b>5</b> Book domino	23
<b>6</b> The first sentences	24
<b>7</b> Developing hypotheses	25
<b>8</b> Books in goody bags	26

---

### Reading and understanding books and texts

<b>9</b> Free reading sequences (individual readings)	27
<b>10</b> Reading out loud and creating recordings for others	28
<b>11</b> Reading in groups or as a class	29

---

### Reporting from readings

<b>12</b> Who can guess my book?	32
<b>13</b> Riddle string	33

---

---

<b>14</b>	Developing questions about texts	34
<b>15</b>	Creating an ad poster for a book	35
<b>16</b>	“Book Slam”	36
<b>17</b>	“Book Dating”	37

---

### Reflecting on readings

---

<b>18</b>	Reading out loud: a self- evaluation	38
<b>19</b>	Rethinking one’s own reading	39

---

## **II** Part II: reading practice

### Reading skills

---

<b>20</b>	Recognizing letters automatically	44
<b>21</b>	Reading words faster and faster	45
<b>22</b>	Seeing sentences as a whole	47
<b>23</b>	Understanding what I read	48

---

### Reading fluency

---

<b>24</b>	Practicing reading fluency	50
-----------	----------------------------	----

---

### Reading strategies

---

<b>25</b>	Strategies before reading	53
<b>26</b>	Strategies during reading	54
<b>27</b>	Strategies after reading	55

---

## **III** Part III: literary-cultural education

<b>28</b>	Listening	60
<b>29</b>	Characters in a book	61
<b>30</b>	Figuratively envisioning a place	63

---

<b>Bibliography</b>	64
---------------------	----

---

---

## Explanations, abbreviations

First language: Also mother tongue or family language: the first language a child has learned and speaks at home. Some children have two first languages.

---

School language: The language that is spoken in the schools of the host country. In addition, the local dialect may count as an environment language.

---

Abbreviations: S = student  
T = teacher (instructor)

---

### Legend

for indications referencing organizational form, class, time requirements concerning teaching proposals:

---



IW = individual work

---



WP = working with a partner

---



SG = small group

---



WC = whole class

---

1<sup>st</sup>–9<sup>th</sup> grade

Suitable for... to... (e. g. 2nd– 4th grade).  
Keeping in mind that this designation may vary according to the requirements of the individual students.

---

10–15 minutes

Approximate time requirement, e. g. 20 minutes.  
(Estimated time varies, must be determined by the instructor according to the level and the requirements of the class).

---



# Preface to the series “Materials for heritage language teaching”

Heritage language teaching (HLT), or mother-tongue teaching, known mostly as “Herkunftssprachlicher Unterricht (HSU)” in Germany and Austria and “Unterricht in Heimatlicher Sprache und Kultur (HSK)” in Switzerland, plays an important role in the development of a child’s identity and language. It promotes multilingualism and serves as a valuable personal and social resource. The awareness of this fact has long been borne out by research and framework guidelines, such as the recommendations of the Council of Europe R(82)18 and R(98)6. Nevertheless, this kind of instruction for the most part still takes place under more difficult conditions than regular curriculum classes. Various factors are responsible:

- Heritage language education is on an insecure footing institutionally and financially in many places. In Switzerland, for instance, heritage language teachers almost everywhere are paid by the country of origin or even the parents.
- Heritage language classes are often poorly coordinated with regular classroom instruction; contact and cooperation with regular curriculum teaching staff is often very poorly developed.
- Heritage language classes often occur only two hours per week, which makes constructive, uninterrupted learning more difficult.
- Heritage language classes are mostly optional, and the commitment on the part of the students is not very strong.
- Heritage language classes involve multiclass teaching as a rule, with students from the 1st to the 9th grade joined into a single class. This requires a great deal of internal differentiation and didactical skill on the part of the instructor.
- The heterogeneity of the student body in heritage language classrooms is extremely high in terms of the students’ linguistic competence as well. While some have acquired at home good proficiency in both dialect and standard use of their native language, others may speak only dialect. For second or third generation heritage speakers who have already resided for many years in the new country, the language spoken there (e.g. German) has become the dominant language, while their command of the first language is limited to dialect, transmitted exclusively orally, and with a vocabulary reduced to familiar issues.

- The heritage language instructors have generally received a good basic education in their countries of origin, but they are not at all prepared for the realities and the challenges of teaching in a multiclass environment in the migration destination countries. Professional development opportunities in the host countries exist for the most part only to an insufficient extent.

The series “Materials for heritage language teaching” supports the teachers of native language education classes in their important and demanding task and thereby hopes to contribute to the optimal quality of this kind of learning. The review of the backgrounds and principles of the current pedagogy and didactics in western and northern European immigration countries (c.f. the volume Foundations...) furthers this goal, supported with concrete practical suggestions and models for the classroom in the workbooks “didactic suggestions”. Their main emphasis is the promotion of linguistic competence. The didactical suggestions purposely revert to the pedagogical principles and procedures that are familiar to the students from the regular curriculum and its teaching materials. This familiarity brings heritage language education and regular curriculum instruction in close contact and ensures the greatest possible coherence between the two. As the teachers of the heritage language education programs familiarize themselves with the didactic approaches and specific proceedings that are currently used in the regular curricula, they receive further training and, it is hoped, a strengthening of their stature as partners of equal value in the educational process of the students who are growing up bilingually and bi-culturally.

The series “Materials for heritage language teaching” is published by the Center for International Projects in Education (IPE) at the Zurich University of Teacher Education. It is developed in close collaboration between Swiss and other West European specialists on the one hand, as well as experts and practicing instructors of heritage language programs. This ensures that the offered information and suggestions reflect the real circumstances, needs and possibilities of heritage language programs and meet the objective of functionality and practicality.



# Introduction

## 1. Reading in the heritage language: possibilities and challenges

That people should be able to read and write in their heritage language, native language or first language is important and self-evident; those who lack these literal skills inevitably remain illiterate in their first language. They lose the connection to its written culture, and their bicultural-bilingual-biliteral development is seriously jeopardized. On the other hand, those who possess literal skills in their first language as well, will have access to rich and numerous possibilities. These range from access to the literature of one's own people and the possibility of participating in its written culture from the migration, to obtaining information in books and electronic media, and to complement and perhaps increase one's professional opportunities.

At least with those languages that use the Latin alphabet, one would not expect at first sight major problems in terms of reading. Quite wrong: problems and difficulties do indeed exist. These can be summarized in three groups:

### **a) Problems with grapheme inventory (special letters and accents) and the sequence of the letters.**

Most languages have special characters (ë, ç, đ, ċ, ş, ğ, ı, â, æ, ã etc.). These graphemes are not being taught as part of literacy training in regular classroom instruction in the immigration countries. The same holds true for different phonetic values of individual graphemes (example: <z> has the phonetic value of ts in German, whereas in most other languages it signifies the voiced s; <c> has the phonetic value dsch in Turkish, in the Slavic languages it has the phonetic value of ts and in German the phonetic value of ts or k). Many phonetic values are described differently, depending on the language. Thus, the German sound [ʃ] corresponds to <sch> in English, for example, and is rendered as <sh> in Albanian, in Turkish <ş>, and in the Slavic languages as <š>, etc. The sequence of letters in dictionaries is not identical everywhere either; for instance, the letters ö and ü in Turkish follow the o and u- words, whereas they are integrated with them in German, and do not exist at all in English and Portuguese. The children have to learn all these special features at home or in HLT, if they want to read and speak fluently in their first language. In order to avoid confusions when learning the language of the host country, many HLT instructors introduce these special features only at the end of the first year of classes or at the beginning of the second year. In the case of the non-Latin alphabets, the entire alphabetization has to occur in the first language, of course.

### **b) Problems with the standard variation of the first language:**

Many children and adolescents speak their first language at home only in a dialectal variant. This may at times vary greatly from the standard language (e.g. in many South Italian or North Albanian dialects) such that it may pose serious problems with reading. (This is a lesser issue with writing, as one can write in dialect as well). A careful introduction into the standard and written language is one of the most important tasks of HLT when it comes to preserving the access to one's own written culture. This is especially important for children from educationally disadvantaged families who have little or no contact from home with the written or standard variant of their language.

### **c) Problems in conjunction with lacking reading tradition and parental support.**

This dimension of difficulties and problems is not just inherently specific for HLT, but rather depends on the parental educational advantage or disadvantage. Overall, it can be said that children and youths who are accustomed to reading books and dealing with writing are much better positioned for success in our written and text-oriented schools and societies than those who lack these important prerequisites. This pertains particularly to reading in the first language, whereas reading in the school language is actively practiced in regular classroom instruction for years. HLT can play an important role in compensating for these deficits. This is all the more significant as the acquired competences benefit the respective students not only in HLT, but also in their regular education classes. More detailed information about this issue can be found in the handbook "Foundations and Backgrounds", chapters 1, 2 and 8, also in Sträuli et al. (2005), pages 130 ff. and in Bibliomedia, QUIMS (see bibliography).

In answer to the question "What are the students' main problems in terms of reading in their first language in HLT?" we conducted a small survey among HLT instructors prior to the publication of this issue. The answers correspond to the above three categories, as evident from the following examples:

- 
- "The students are unable to clearly distinguish between the pronunciation of the letters q, ç, gj, xh, sh, etc. in Albanian, and they also have problems with our standard language".
- 
- "The students have difficulties with the special characters of the Turkish language. Furthermore, they do not recognize many words, as their vocabulary is very small".
- 
- "One problem are the uncertainties with the special letters of our language and the pronunciation of the different letters. Naturally, the students have not learned these differences in regular classroom education. I have to teach and practice this very carefully with the little ones, otherwise they continue to make mistakes in their pronunciation or they confuse many letters".
- 
- "The low number of weekly hours and the students' diluted contact with the standard language renders learning to read more difficult. Most of the students speak dialect at home and are barely supported by their parents".
- 
- "Reading in the first language is a problem, as most of the students only do it in HLT, but rarely ever at home. Another difficulty is that they only speak dialect at home. Therefore, they have difficulties with reading and understanding of words in the standard language, which they partially don't understand".
- 
- "The students' main problems are the near absence of reading practice. There are various reasons for this:
    - a) The parents also read very little; the children rarely ever see them reading.
    - b) Stories are not read to, or rarely ever read to, the children.
    - c) During their stays in their country of origin, they mostly use oral communication".
- 
- "The students are generally poorly motivated for reading. It is even lower for reading in their native language, because they have difficulties with it".
- 

Reading competences (as well as writing competences and other learning techniques and strategies) are not bound to a certain language. Once they are acquired, they can be easily transferred to a person's other languages as well as used in these languages. It is for this reason that HLT efforts to further students' reading abilities in the first language also serves them well in their regular education classes. It would therefore be highly desirable that HLT and regular classroom education cooperate as closely as possible in order to build up students' reading competence. This aspect, too, is referenced in our survey:

- 
- "Students who read well and fluently in their school language, also read better in their first language. The reading competences transcend languages."
- 
- "Reading is a technique that has to be practiced. A person who has mastered this technique in one language will be able to use it as well for any other language. Moreover, if a child likes to read s/he likes to read in all languages. (...) It is important to link global, purposeful reading with all languages and to practice it in all languages. It must be clear to the instructors and students that they can apply most of the reading strategies and techniques in all languages".
- 
- "A close collaboration between the teachers of HLT and regular school would be of great advantage. This way, both could work specifically and efficiently to support the students in the area of reading".
-

## 2. Goals and structure of this brochure

Reading and writing in the first language, as described above, are not abilities that one can well forego in the migration, like any other skill. That students be able to obtain and work with written information in their first language is a rather indispensable prerequisite for their holistic bilingual-bicultural development. In addition, a good mastery of the first language also supports the acquisition of literal abilities in the school language of the host country. As a highly effective selection competence, it is also the basis for school success in regular education classes.

The present publication attempts to support the teachers in their demanding task of promoting the students' ability to read in their first language and to discover the joy of reading. Moreover, it will provide instructors with examples and ways to purposefully further different areas of reading competencies, such as improving reading fluency, textual comprehension, as well as discovering the joy of reading creatively designed texts with their students.

The introduction to this workbook offers some insights into important issues and aspects of current reading didactics with a focus on certain points that are of specific importance for HLT. The second, practical part includes 30 specific practice suggestions for the areas of reading promotion, reading training and literary-cultural education. These suggestions are intended specifically for the teachers. They can be implemented easily without time-consuming burdens on classroom instruction and with reading materials which are being discussed anyway. Most of the suggestions can be implemented – with some age-specific adjustments – for students of all age levels. This approach responds to the circumstances in HLT where most classes are age-heterogeneous and taught jointly at different levels.

---

## 3. Key aspects of current reading didactics

Reading cannot be learned from one day to the next. The path from slowly deciphering individual letters all the way to fluently reading a whole book is long, often difficult and arduous. Most children and adolescents would want to be accompanied and supported repeatedly in this process. Important to this process are the adults, the parents and teachers who foster the children's often very different reading interests. They serve as role models who read to and discuss stories with the learners. This can and should begin long before children begin school: if the parents read and look at picture books and talk about them with their very small children or read stories to them and talk

about them, this represents a very early, particularly effective form of early reading promotion. According to the experience reports of adult readers, the most effective educational promotion of reading for young people are teachers who reveal themselves as readers, who take an interest in the students' reading materials and interests, who know many different books and can initiate and moderate inspiring discussions with the learners about the materials read.

To read well and with pleasure -both aspects are important preconditions for a successful reading development, and they are interdependent. Only those who have experienced the pleasure of texts and what they convey will want to undertake further, perhaps initially more laborious steps. Conversely, the students must have acquired certain skills in working with texts, pictures and contents, in order to engage themselves joyfully and inquisitively in further readings.

In doing so, the encouraging -furthering approach to teaching reading must keep an eye on various sub-areas. Those can be differentiated in three aspects: furthering of reading, reading training, and literary-cultural education. These three areas complement each other, but the required competences for them often cannot be practiced at the same time and with the same text. This applies, of course, particularly for native language education and reading in the native language. The individual sub-areas, however, can be taught and practiced with differentiated texts and assignments in a number of ways. This has a positive effect on the acquisition of literacy in the first language as well as in the language of the host country. The present text offers a rich collection of ideas and assignments for all three areas.

### a) Reading promotion

The goal of reading promotion is to win over the students for reading. They should become curious about texts and books, should be able to choose among them according to their interests, they should experience the great variety of books and texts, and how exciting it can be to access their contents by reading. The ultimate objective would be that reading becomes a natural daily activity for the students - in school as well as at home - in the first language as well as in the language of the school.

In view of this goal, it is important to offer a broad and exciting selection of texts so that mostly all students can find readings of interest that they can delve into. A diverse selection in this sense should include not just books, but also magazines, newspapers, comics, photo and picture books, as well as a broad spectrum of electronic texts, ranging from a website with information about non-fiction topics, to a chat forum and e-books.

In dealing with students who possess little reading motivation, it may be necessary, at times, to explicitly demand the necessary silence for reading. Those children and youths must also learn to sit quietly at their desks in order to read their books and texts, and they must be accountable to themselves about what and how much they have read. This way a certain level of perseverance may be acquired and practiced which ensures that they not repeatedly abandon their chosen readings.

An educational approach that promotes and encourages reading also ensures that students recognize adult reference persons and same-age readers with whom they can discuss and exchange information and experiences with their readings. In mixed-age classes or groups, older students may serve as important role models.

Reading promotion pursues most of all the following objectives:

- It should first and foremost instill an interest in books and other media with writing and pictures.
- It should enable students' competent handling of large textual varieties and also provide pertinent learning assistance and strategies.
- It should open up all avenues to the world of writing and demonstrate that reading is an activity with everyday relevance and many relationships to one's own living environment (texts relating to personal interests, different media for the same topic, usage of texts from the first and second language, etc.). This way new readers can and should also be won and motivated.
- The promotion of reading should ultimately lead to an enjoyment of reading, so that children and youths not only read texts and books in school, but that reading and dealing with texts in their first and second language becomes part of their daily routine as a matter of course.

## b) Reading practice

A good reading training aims at fluent and comprehensive reading through targeted practice. To be able to read well and fluently and to also comprehend what has been read is challenging. Many children and youths – particularly those from educationally disadvantaged families – tend to become overwhelmed if they are not supported with specific measures. Different practice formats at all class levels therefore are necessary for an encouraging reading environment. These exercises focus on the practice of basic reading skills, reading fluency (accuracy and routine) and reading strategies (assistance to help better understand difficult texts).

The training of reading is therefore not primarily guided by enthusiasm for reading. Its aim is rather a targeted practice to improve students' reading abilities. This occurs with structured skills practice, repeated reading exercises with the same text and with strategies, designed to help students better comprehend more challenging texts as well.

Reading didactics distinguishes between three central training areas. It goes without saying that these apply as well for reading practice in the first language:

### 1. Reading abilities

This area comprises primarily the rather technical aspects of reading on the level of the letter, word and sentence, where many students – particularly the younger ones – are not sufficiently competent. They experience problems with decoding, recognizing of graphemes and letters in their native language and linking of sentence parts and sentences. This applies particularly when the sign system and phonology of the native language is different from the school language (see above). To this end, HLT can offer effective support with a careful introduction into the writing system and the graphemes of students' native languages as well as with systematic vocabulary development and dealing with more complex syntactical structures.

### 2. Reading fluency

The training of reading fluency is – unfortunately - not yet fully anchored in educational practice, although it is of significant relevance. A learner who routinely reads relatively fast and without errors "gets through" a text and experiences correspondingly less difficulty in understanding its content. This is because practiced readers are able to concentrate more on understanding the text, as the more technical aspects of their reading process are largely automated. Readers with

weak fluency, on the other hand, must invest part of their energy for decoding and other technical aspects of the reading process. New results from Germany also show that students were able to construct a new and more stable self-concept in terms of their reading activities in the course of this reading fluency training. After completing this training phase, they felt more competent and characterized themselves more frequently as good and motivated readers. This in turn leads to a higher motivation for reading. It confirms a fundamental truism: Those who read well, like to read. Those who like to read, read a lot. Those who read a lot, read well.

### 3. Reading strategies

Good, well-practiced readers know what they can do in order to understand a text as quickly and fully as possible. They often apply different strategies (sometimes unknowingly) for textual interpretation and do not just read on, hoping for the best. For instance, they previously prepare a tentative reading plan and read the text according to this plan and their goals in different ways. In teaching methodology there are three different ways of reading and reading comprehension, which should be deliberately practiced in class – naturally also in HLT – based on appropriate texts:

- Targeted reading comprehension: this involves a targeted search for a certain information, i. e., in a dictionary or a phone book, in a timetable or in a non-fiction text.
- Global reading comprehension: the goal here is to understand the essence of a text, without necessarily storing every minor detail. This kind of reading is frequently used in connection with literary texts or newspaper articles.
- Detailed reading comprehension: is required when mostly every detail of a text must be understood (e.g. a recipe or instructions for a test, etc).

Practiced readers continuously verify the comprehension process during reading and know how to address any arising comprehension difficulties. A person's knowledge of reading strategies and their independent application represents a significant aspect of reading competence. The actual teaching of these strategies works best by jointly working through texts with the class, e.g. as part of an emerging classroom discussion. Following a careful introduction, these strategies naturally have to be practiced over and over again with different texts until they are internalized by the students. The approach and selection of strategies should vary, depending on the nature of the texts

and their content (e.g. strategies for understanding non-fiction, strategies for summarizing stories, strategies for understanding charts and graphs, etc.). Pertinent materials and suggestions can be found in the volume "Didactic materials 5: teaching of learning strategies and techniques in HLT", chapters 2 and 3 which offer additional strategies for reading and using educational resources (dictionaries, reference works, etc).

The present volume aims to present a broad range of practice exercises and examples in the areas of reading skills, reading fluency, and reading strategies which, of course, need to be adapted according to the requirements of a particular class or group. The weaker readers should practice as much as possible with the exercises in the area of reading abilities. Stronger readers may forego some or all of the reading skills exercises and use that time for their personal reading practice. It is particularly useful to practice reading fluency based on texts from everyday classes.

### c) Literary-cultural education

Literary-cultural education intends to provide students with practical experience working on creative (literary) texts. This includes interacting with sensual and playful language in poems and language games or enjoying crafted literary texts. Of primary importance for HLT are, of course, native language texts and the age-appropriate teaching of a basic knowledge of one's own literary history. If upper level HLT classes draw comparisons between native language literature and the literatures of the host country and the world, their literary horizons is expanded.

The primary goal for students is to develop an aesthetic sensibility which will serve them well for continued experiences with poetically crafted texts. The culture of a country and people is largely reflected in texts and books, including traditional fairy tales and legends, as well as poems and stories or contemporary novels. All these genres comprise certain linguistic criteria in terms of content and form, which differ significantly from those of everyday or non-fiction texts. These differences can, of course, be developed with older students. The main emphasis, however, is not to analyze literary texts, but rather to get acquainted with the literature in the first place, to be able to read and enjoy it, and to become familiar with it over time.

Rhymes, verses and language rhythms, and also reading situations can already produce intensive, sensual-aesthetic listening experiences in very small children. Those who have experienced such listening experiences will continue to listen with their "inner ear" even later on when reading literature silently. This is of special importance when reading lyrical texts.

With the support of the teacher and with appropriate exercise assignments, the shared in class readings of creative language – e. g., a poem or a story – can be the basis not only for enjoyment but also for the understanding of a text on different levels. Gaps in comprehension may be closed through mutual exchanges, and awareness is raised and brought up for what is read between the lines. Pictures and scenes are collectively imagined and played (playing back is an excellent form of comprehension control and for deepening the understanding). The characters and acts of individual figures can be interpreted and discussed, and students may exchange their experiences of reading a literary text. The collective reflection, discussion and working through a text helps students to truly understand the meaning of a text. This approach is more promising and leads to more insights than a solitary contemplation of readings alone in a room.

---

#### 4. Additional aspects specifically related to reading in the heritage language education classroom

Reading and reading promotion in HLT differs from reading education in the regular classroom primarily in terms of the language of the texts and their cultural provenience, as described above. The work and training areas are largely identical, as are the goals of literary socialization and promotion in the first and second language, however. Consequently, the following sections a) and b) are not just HLT-specific, but rather accentuate two general points (which are important for HLT as well).

##### a) Text relief before reading

Vocabulary carries a great deal of importance in reading. Readers often fail to understand a text because it comprises too many words which they don't know. This can lead to great problems, particularly with texts that are written in the standard version of the first language, because many children and adolescents speak the language at home exclusively in dialect.

For this reason, it is important that HLT instructors previously lighten the language burden of the texts and facilitate the access to them (see also Sträuli et al, pages 58 ff). A proven method is to discuss with the students a list of key words and potentially problematic words and phrases in order to clear up difficulties ("Look, we are going to read a text that contains words such as «masonry», «was situated», «creepy» and «knights' armor». We want to clear them up first!"). This allows students not only to tune into the text content; it facilitates activating their prior knowledge, formulating hypotheses, and they understand already a large part of the form and terms that appear in the

standard language text. Other things that facilitate comprehension are pictures that illustrate the events, show details, reflect moods or depict and explain specific content in pictures.

##### b) It is not necessary to always understand each and every word

Readers (and even teachers) often concentrate too much on what is not understood instead of concentrating first on that which has been understood. This deficit-oriented view can be demoralizing.

There is another solution: for instance, when students are asked to underline everything that they have understood when reading. By marking the passages where everything was immediately understood, they begin to realize that generally it was part of a sentence or a few words that they did not understand during the first reading. This tends to increase the motivation to continue reading. Moreover, with the context clues from what has been understood, the remaining comprehension problems can very often be solved.

With many texts, it is not at all necessary that the readers understand each and every word; depending on the educational goals and the type of text, a global understanding (see above) may be quite sufficient. The previous marking of key terms and central passages in the text may be helpful as well. This way, readers know what to pay attention to, and which parts are of special significance. Depending on the educational goals related to work with the text (e.g. a detailed analysis of the content and message), the readings must be followed up with enhanced vocabulary practice. That working with vocabulary in the context of real texts is particularly authentic should be obvious.

##### c) Cooperation with regular classroom education

When HLT and regular classroom instruction work together, this cooperation widens the horizon and deepens the sustainability of what has been learned. This pertains not just to content that was treated jointly (e.g. water or agriculture in the various countries), but includes also many learning techniques and strategies. Since these are almost always supra-linguistic, i.e. they can be applied in different languages, a cooperation between HLT and regular classroom instructors in this area is particularly valuable. This is equally true for the important area of literary-cultural education, where HLT and regular classroom instruction complement each other optimally and could jointly promote the joy of reading.

In places where institutional contacts between HLT and regular classroom instruction are not automatic as, for instance, in Sweden, it is sometimes up to the HLT instructors to initiate contact and to inform themselves about the possibilities of cooperating in the

area of reading. For additional ideas and suggestions, see second part of this volume (also Sträuli et al. pages 116 ff.):

- Reading poems in various languages (and/ or creating poems); learning how to recite, recording of a CD with poetry, creating a multilingual booklet; translation into the school language. Possibly a parents' evening with recited poems in various languages.
- Common reading of a bilingual book or picture book.
- Establishing a book exposition with texts in various languages; each book provided with a brief description on a card.
- Usage of electronic and other sources in various languages for a common factual issue (e.g. Roman era in Germany and in Turkey, etc.).
- Common introduction and application of certain reading strategies or techniques (see part II of this volume and volume 5: Learning techniques and strategies).
- Joint work in establishing a multilingual library in the schoolhouse.
- Cooperation (workshops etc.) within the framework of a project week "Reading pleasure in various languages" or as part of a reading night.

Sometimes there are no possibilities of a cooperation, owing to overload issues. In such cases, we recommend as a minimal solution that HLT teachers request the textbooks from the regular school curriculum in order to apprise themselves of the local didactic approach in the areas of reading promotion, reading training, reading strategies and literary education. Undoubtedly, some pertinent good ideas could be implemented by HLT, and the students' explanations, suggestions and experiences could surely help in this effort as well.

## d) Where to find texts in the language of origin

- Text collections for instructional use

That HLT instructors have their own text collections is clear. These may include literary works, collections of poems and fairy tales, picture books or school books in the language of origin, but also collections of articles, stories, etc., for certain factual topics. Increasingly important are the lists with links to appropriate websites.

Text collections can and should also be established together with the HLT students. An easy to implement, simple solution would be to ask the students and their parents and relatives to provide HLT with reading materials in their language for that purpose. This may include children's books, other books, illustrated magazines, (children's) magazines and comics. Native language text searches in the internet should also be conducted by and with the students. It is important that the instructors support the students in this endeavor and also hold them to a responsible handling of resources (adequate references to sources: assistance with citations, etc).

Important: depending on the region of origin and the political context, the instructor must remain strictly vigilant that no texts of a tendentious nature, national socialist or otherwise provocative character be integrated into these collections

- Text collection for borrowing

Text collections for immediate classroom use are important, but they are not sufficiently large. For the purpose of active promotion of reading in the first language, these collections must be complemented with books and other texts which the students can borrow and read at home. In an ideal case, such titles can be obtained in an intercultural library (see below) or in the library of the school building, if it has multilingual collections. If this is not the case, it is up to the instructor to seek a solution. If s/he has a collection of texts, a simple list of available books will suffice (create a borrowing chart with the book titles and the names of the persons who check them out). Students then can order each week, what they would like to read and return the works they have read. Students should naturally be able to assist with this small library operation. An excellent time for this is summer vacation, where many children spend time in their country of origin and from where they can bring back reading materials. Perhaps a little money could be raised before their vacations (bazaar, parents' event, etc.) so that each child has a small budget. Of course, the choice of titles in terms of political and ideological neutrality must be controlled.

Maybe the school has an available cabinet for the storage of the acquired small library. Even better if the school library (if there is one) also has book selections in the various native languages of the students which are also available to HLT. In places where HLT is well integrated into the regular school system, this should not represent a problem. In any event, such an initiative by an HLT instructor can and will be well worth the effort.

- Public intercultural libraries

Many libraries, particularly in larger cities, have a selection of books (including picture books, and books for children and adolescents) and sometimes also magazines in various languages that can be checked out.

In Switzerland there is an association of these intercultural libraries; see the website <http://www.interbiblio.ch> with an overview of the individual locations and book lending services.

For Sweden, comprehensive information is available on the website <http://modersmal.skolverket.se/sites/svenska/index.php/fer-sprakighet-i-forskolan/kop-lan>

For pertinent library information in Germany, compare the website <http://www.bibliotheksportal.de/themen/bibliothekskunden/interkulturelle-bibliothek/materialien-in-mehreren-sprachen.html>

- Book lending and information about country-specific institutions (examples)

#### *Germany:*

The website of the German Library Association includes comprehensive information and also allows for specific searches. There are materials and information about the following topics: texts for library work, multilingual library glossaries and online dictionaries, listings of foreign language collections in German public libraries, collections of links about language and culture, links to foreign language wikipedia platforms, links to media, newspapers and magazines, text templates for methods of promoting language development and reading. Link: <http://www.bibliotheksportal.de/> and <http://www.bibliotheksportal.de/themen/bibliothekskunden/in-terkulturelle-bibliothek/materialien-in-mehreren-sprachen.html>

The website of the Goethe institute offers valuable information about multilingual books, educational materials for the classroom and a very useful collection of links to other institutions: <http://www.goethe.de/ges/spa/prj/sog/fms/lit/deindex.htm>

Recommendable information and suggestions about parental inclusion and engagement can be found on the website <http://www.mehrsprachigvorlesen.verband-binationaler.de/>

#### *Austria:*

A lot of information and search options can be found through the link <http://www.schule-mehrsprachig.at>

For specific multilingual books for children and adolescents, see <http://www.schule-mehrsprachig.at/in-dex.php?id=11>

Among the wealth of materials, there is also a multilingual children's magazine, which can also be ordered in Switzerland and in Germany. The subscription is free, only the shipping costs are billed. More useful information is also available at the Austrian website <http://www.wirlesen.org>

#### *Switzerland:*

The foundation Bibliomedia in Switzerland has compiled a varied selection of foreign language and multilingual books, which HLT instructors may check out over longer periods of time as well. Books are available in Albanian, Arabic (only children's books), English, Croatian, Portuguese, Spanish, Serbian, Tamil, Turkish. A list on the website shows the selection of multilingual books. The costs of lending vary according to the school location. Instructors should inquire with the school management or contact Bibliomedia directly. Bibliomedia also offers educational materials, lists of books and a collection of current continuing links to the topic multilingualism; see bibliography, title "Bibliomedia, QUIMS". Adress: Bibliomedia, Rosenweg 2, 4500 Solothurn, Tel.032/624 90 20. Link: [www.bibliomedia.ch](http://www.bibliomedia.ch)

JUKIBU (Intercultural library for children and adolescents): this special library in Basel has books and media available in 50 different languages. A current online catalog helps with the title search. JUKIBU also offers regularly the most diverse events. Adresse: JUKIBU; Elsässerstrasse 7, 4056 Basel, Tel. 061/322 63 19. See link: [www.jukibu.ch](http://www.jukibu.ch)

Baobab: the association Baobab is committed to intercultural themes focused on reading and also frequently publishes multilingual books. Link: <http://www.baobabbooks.ch>

Network sims: this platform carries lists of books in various languages, which can be ordered. It also has many helpful downloadable teaching materials available for promoting the language development of students in the migration: <http://www.netzwerk-sims.ch>



Bischu – Handbook for the collaboration of library and school; published by the Department of Education of the Canton of Zurich. This handbook offers varied and valuable suggestions. It shows the extent of their efforts and that collaboration goes beyond the mere lending of books. Link: <http://www.bischu.zh.ch>

*Sweden:*

Comprehensive information about publishers, libraries, book lending possibilities, etc. can be found on the above referenced website <http://modersmal.skolverket.se/sites/svenska/index.php/fersprakighet-i-forsko-lan/kop-lan>

General: the foundation of European National Libraries offers links to the various partners within Europe. Link: <http://www.theeuropeanlibrary.org>

# Part I: reading promotion



# The suggestions for exercises and teaching in this part are divided into four sections:

---

## Meeting books and texts

Suggestions for exercises 1–8:

The particular focus is to become acquainted with different books and texts as an important element of reading motivation.

---

## Reading and understanding of books and texts

Teaching suggestions 9–11:

Teaching suggestions 9-11: This area focuses on reading per se and shows examples of how to create diversified reading lessons and how students can plan and reflect on their own reading process.

---

## Report from readings

Teaching suggestions 12–17:

This section deals primarily with reflecting on what has been read, i.e., the discussion about contents. It offers various proposals about how to share reading experiences in class.

---

## Reflecting on readings

Teaching suggestions 18–19:

The two teaching suggestions in this rubric support the important competence of student's ability to assess themselves and their abilities and to become aware of their reading habits and preferences. This contributes to the students' growth as independent and mature readers.

## 1

## Reading out loud as a ritual

## Goal

*Reading out loud is one of the easiest and at the same time most effective methods of furthering the motivation for reading. In reading aloud, students can simply enjoy the stories or a book. They experience just how fascinating stories can be and that it pays off to be able to read well and fast.*

1<sup>st</sup>–9<sup>th</sup> grade

15–20 minutes



Materials:  
book (as continuation) or a  
collection of shorter texts.

## Procedure:

Each HLT unit (e.g. a weekly double lesson) begins with a sequence of reading out loud. The students sit comfortably while the instructors read from a book to the class for at least 15 minutes. The main purpose is to enjoy and to immerse themselves into a story.

## Remarks:

- If a book is read aloud (not as individual short stories), it is particularly important that the ritual extend itself over a longer period of time and without interruptions, as the students might otherwise lose the story line.
- HLT classes are often simultaneously frequented by students from different classes. In order to meet the needs of a heterogeneous group, the text read aloud must be chosen so that is most widely appropriate for all age groups. Alternatives: short texts may be more appropriate for the lower, middle, and upper levels.
- During the read aloud sequence, the class must be quiet. Students may draw something, but nothing should be permitted that could make noise and distract.

## Variants:

1. Students can take part in deciding on a text, based on a selection, previously prepared by the teacher. Students may, of course, also bring a text to class for reading aloud.
2. It must not always be the instructor who reads the books or stories; students may also perform this task. It is important, however, that reading aloud by students is previously practiced intensively. To that end, students should be given a week's time to practice reading at home. (See also the support for one's own reading aloud on page 38).
3. The text that is being read out loud is always recorded by tape recorder or other media (dictaphone, cell phone, computer). The created audiobook may also be checked out; copies might be lent to other classes. Variant: the older students read and record a book for younger students on a recording device. See also the teaching suggestion 10 "expressive reading out loud for others".

# 2

## Establishing a small library in the first language.

### Goal

Students get to know a broad and stimulating array of text offers in their first language. They exchange information about materials they have read (or about picture books) and can choose among different books. They become acquainted with the rules of a library.

1<sup>st</sup>–9<sup>th</sup> grade

10–20 minutes



#### Materials:

Several books, picture books, comics, illustrated magazines for children and young adults in their native language.

#### Procedure:

- The project is started as a shared enterprise. We want to create a small library of a wide variety of texts (books, picture books, reference books, etc.) in our own language. To be clarified: who can bring what? Where should the books and texts be stored (is there maybe a cabinet or a bookshelf in the school building or in the school library for that purpose)? How should the borrowing of books function?
- The students bring different kinds of reading materials from home and present them to the class. All titles are subsequently listed (e.g. in form of a simple borrowing chart), and placed on a shelf if possible.
- The students now can give each other reading tips or exchange books and magazines with one another. Ten minutes a week could be reserved for this activity. Who takes which book is recorded in the borrowing chart. Two students are selected to assume control of the library, e.g., for a quarter, and to ensure that all borrowed books are returned again in good condition.



#### Remarks:

- As stated in the introduction, chapter 4d, the students could be asked to bring back from their long vacations reading materials in their native language (to defray the costs, maybe a bazaar, or parent event, etc. might raise some money for that purpose).
- The important thing is that the small HLT library contain reading materials for all age levels, as well as children's encyclopedias and a dictionary.
- The library may also comprise audio books, be they bought or home-made (see also the teaching suggestions 1 and 10).

# 3

## Checking out books at institutions like “Bibliomedia”

### Goal

*Students should find reading materials in their first language that are of interest to them, thereby increasing their motivation for reading and their reading competence. In looking for appropriate reading materials, they can avail themselves of the collections by specialized institutions, such as “Bibliomedia” in Switzerland. These institutions where one can borrow books in different languages for longer periods of time, exist in many countries.*

1<sup>st</sup>–9<sup>th</sup> grade

15–30 minutes



Procedure:

- An institution’s library holdings in the students’ first language are collectively reviewed and discussed. Appropriate materials are selected and an order is placed.
- Upon receipt of the books, the students may take them home to read. For 4–6 weeks, HLT classes reserve 15–30 minutes during which students discuss their reading experiences and make recommendations.
- Two students are selected to assume control of the process and to ensure that all borrowed books are returned in good and clean condition.

Remarks:

- Local librarians or the teacher who is responsible for the library in the school building may be able to assist students in searching for appropriate institutions with native language collections.
- Information about and links to various institutions in Germany, Austria, Sweden and Switzerland can be found in the introduction, chapter 4d, “Books and informationen in country-specific institutions”.

# 4

## A library visit

### Goal

*Students visit a library (if possible a multilingual library) and thus experience there the extent and variety of the library collections. They learn about the holdings, titles and the library’s structure, and inform themselves about the circulation conditions. They should also perceive the library as a place of learning, i. e., as a focal point for obtaining information about specific themes.*

1<sup>st</sup>–9<sup>th</sup> grade

45–90 minutes



Procedure:

- Most libraries are happy to receive classes and to introduce them to the library systems. Many libraries, most of all the larger ones, hold titles in various languages to lend.
- The trip to the library should become a habit for all students. In the library they should find those reading choices that really are of interest to them. This could entail very different topics, such as cookbooks, magazines about football, love stories or comics. There are often computers available in the libraries, which can be used to search for texts in the native language.

Remarks:

- For additional information about intercultural libraries and school libraries with expanded multilingual collections, see chapter 4d in the introduction. The multilingual expansion of a school's internal library is an optimal project of cooperation between HLT instructors and regular classroom teachers; see also chapter 4c.
- It would be best if the library visit could indeed take place in a multilingual or intercultural library, where students can also find books in their own language. Even if that is not possible, the library visit should not be waived, particularly since it may open doors to an entirely new world and wealth of information for students from educationally disadvantaged families. Moreover, the libraries always have reference works, etc., that are valuable for HLT as well.
- Before the library visit, it is useful to check with the regular classroom instructors about the extent of the students' introduction to and use of the libraries and what could perhaps be done to deepen their understanding.
- Prior to the library visit, it is important to register and establish contact with the employees. It may be possible that a library prepares or even especially orders a selection of books in the native language of the students. It is equally important to clarify the circulation conditions prior to the visit. In many communities the borrowing of library resources is free for students.
- If possible, each and every student should borrow a book. In subsequent classes they should be given the opportunity to briefly present it to the other students in the class.

# 5

## Book domino

### Goal

*Domino can also be played with books. This is an unusual way to acquaint students more closely with the book holdings (e.g. from the library) so they learn about and get to know new books (including from private collections).*

1<sup>st</sup>–9<sup>th</sup> grade

20–30 minutes



Materials:

Many different books, picture books, magazines, etc.

Procedure:

- A stack of books is distributed in class, so that every student (or group of 2–3 students) has three to four books each in front of them. The age of the students must of course be considered when distributing the books, and beginners must naturally be supported. They all have five minutes to become acquainted with the books. They look closely at the cover, read the blurb, and browse through the text. Maybe there are illustrations, an index, chapter divisions, or there is a short portrait of the author, etc. The goal in this phase is that students acquire the knowledge of characteristics for the books which they can later use in the game.
- The teacher then describes a book by way of the recognized characteristics, i.e., s/he could state "it is a picture book, it is colorful, the theme is nature in our country of origin". Pursuant to that, a matching "stone" is placed next to it as in the traditional game of domino, i.e. a second book with one or more matching characteristics (see below). The person who wants to add a book next to it, explains why it belongs there. The





choice must be justified by an identical characteristic; the group decides whether the criterion matches. It is permissible to use simple characteristics (e.g. the cover is also blue, it also was written by a woman, the title also begins with "The...") to more complicated, perhaps content-related reasons (such as: the book is also a thriller, the main characters are also sisters, the story also takes place in Turkey).

- The game either lasts until all books are integrated into the domino, or it will be cancelled after 10–15 minutes. It can be followed by a short discussion with the question "which ones of the books that were placed on the table would you particularly like to read"?

## 6 The first sentences

### Goal

*With this idea, the students become acquainted with different books and texts (articles, etc.), they make hypotheses and thus can be encouraged to read the entire text. Maybe they write their own story, based on a first sentence that they like in particular.*

2<sup>nd</sup>–9<sup>th</sup> grade

60 minutes



Materials:  
A selection of different books and magazines (provided by the teacher),  
A3 paper

Procedure:

- The first sentence is of vital importance for many authors, and quite often for the readers as well.
- The students look in books and magazines for those first sentences that they like particularly well. The teacher, or an older student, may assist the younger ones. The students write the selected sentences legibly on a paper (A3 format). Possibilities for further activities (in groups or as a whole class):
  - a) The students read the sentences and try to find out from which book or magazine a certain sentence might have originated.
  - b) The students make assumptions about what kind of story this could be, based on its first sentence. They also try to guess the genre of the text (thriller, fairy tale, newspaper article, realistic story, nonfiction, operating instructions, etc..).

Variants:

- Students select for the posted beginning sentences one that they like best and invent their own story based on it. Their invented stories will then be compared with the real texts.
- The students select the last sentences from different books and other texts, and then try to develop hypotheses from the end about the content or the origin of the text, based on the last sentences (from which book...).
- The following exercise #7 (developing hypotheses) is a good expansion step.

# 7

## Developing hypotheses

### Goal

*An important motivational factor in reading books of fiction is the fact that the plot can be compared with one's own expectations and assumptions. A person's assumptions may thus be confirmed or turn out to be false. This exercise sharpens the students' awareness for formulating hypotheses and semantic expectations.*

2<sup>nd</sup>–9<sup>th</sup> grade

25–45 minutes



Materials:  
Different books  
(previously prepared by  
the instructor)

Procedure:

- The students read in teams of two the beginning (e.g., the first chapter or the first page) of a story. The material can also be read or told in part or its entirety to younger and weaker readers (teams of younger and older students can also be formed for this purpose). Depending on the make-up of the class, different books can be suggested for this idea (tailored according to age, gender, and interest).
- After that, the teams of two discuss and list their hypotheses about the further developments (how the story could continue, what would be exciting, creepy, funny, etc.?)
- The teams present their hypotheses in class. Someone who knows the book, or the story, reacts and reports how the text actually continues. If no one in the class has already read the text or the book, the students review their hypotheses themselves. They read the book and compare their suppositions about the development of the story with the original.

Comments:

For a good and simple preliminary exercise, see Exercise #6 (The first sentences).

Alternatives:

- If all or several groups have read the same first chapter, they engage in a debate: Which hypothesis is the most likely, and why?
- This exercise is also suitable as a lead-in to a collective reading. The beginning of this material is read aloud; all students write down their hypotheses for the text. These will then be hidden in a treasure chest. At the end of the communal reading, the class checks if one of the hypotheses was correct.

# 8

## Books in goody bags

### Goal

*Little children, notably, like surprises. With this idea, they become especially curious about the content, which can also increase reading motivation.*

1<sup>st</sup>–9<sup>th</sup> grade

30 minutes



Materials:  
Different books,  
gift wrap paper.

Procedure:

- The instructor places one book for each student into a bag, made of colorful gift wrap paper (subsequently this can also be done by older students). All these goody bags are then placed into a basket and presented to the class. It might be useful to use different colors for different age groups (red bags = for the little ones, blue: 4th–6th grade, green: 7th–9th grade).
- Each child may take a “goody bag” and unwrap the book hidden in it. At least 10 minutes should now be allocated for a first reading, leafing and browsing through the book. If a child already knows the book or is absolutely unable to do anything with it, s/he may exchange it through the teacher.
- At the end of the sequence, the students take the books home to read or have it read to them. After a week or two, the books are returned to the school. The students tell each other about what they have read, compare theirs with others, and give each other reading tips.

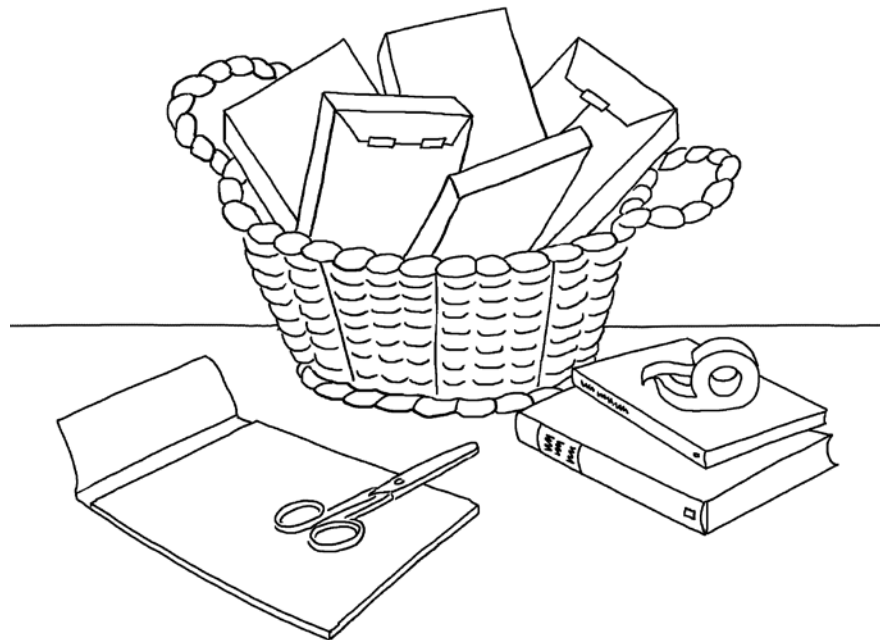

Alternatives:

In the goody bags or packages, respectively, there are books which the students already know (e.g. books which the instructor had read to the students in the course of the year, or which had been presented by other students). The students inform themselves one more time precisely about the content of their book (without showing it to the other students) and write down riddles for it. These questions are then posed to the other students who will try to guess the name of the book in question. Example for riddle questions: “the main character’s father in my book is a king”, “the story of my book takes place in our native country about 1000 years ago”, “the main character in my book has two red pigtailed”. The first information should be very general; still, if nobody guesses correctly, more and more specific information is made available. (See also the idea #13 riddle string)

## 9

Free reading sequences  
(individual readings)

## Goal

*In addition to working with texts as a class, students sometimes need time to read on their own, at their own speed and according to their personal interests and possibilities. This can significantly increase their motivation for reading as well as their competence.*

1<sup>st</sup>–9<sup>th</sup> grade

20–30 minutes



## Materials:

Books, magazines, practical and everyday texts, possibly selected pages from the internet.

## Procedure:

The free reading sequence lasts 20–30 minutes; it can be complemented with a discussion where all students report about their readings, ask questions, or make recommendations.

## Suggestions:

- Free reading sequences should take place regularly. This works well with heterogeneous HLT classes and sequences, during which the instructor works individually with different age groups.
- In free reading sequences, the students can mostly determine for themselves what they want to read. They may retreat somewhere for that purpose, but must do nothing else but read.
- In order to use the free reading time as productively as possible, students must learn how to make a reading plan, as well as how to keep a reading log. The reading log may be useful for later discussions about one's own readings. Specific suggestions for both plans are found in teaching suggestions #11.
- These reading sequences must, however, be clearly structured for children and adolescents who are not used to concentrate for 20 minutes on a single task by themselves, or who have not yet acquired the ability to immerse themselves quietly in a book. Clear guidelines and instructions are necessary, at least in the beginning. This includes that noise and distractions are prohibited during these sequences, that students must plan their reading time beforehand, and that they are accountable for their work and must report after the sequence what and how much they have read.
- Alternatively, a good complement to free reading sequences is reading in groups or as a class, as described in #11 below.



# 10

## Reading out loud and creating recordings for others

### Goal

*This idea pursues two objectives::*

- 1. For one, students should learn how to read a text fluently and expressively, so as to record it on a recording device.*
- 2. For another, it should help to further the interest in texts among the younger and weaker students, who will have an opportunity to listen to these sound documents (just like audio books) at home or in school.*

2<sup>nd</sup>–9<sup>th</sup> grade

30–45 minutes



Materials:

Different texts (short stories, poems, interesting articles, jokes, episodes, books, etc.), recording device

Procedure:

- First, the teacher explains to the students what constitutes “beautiful” expressive reading out loud, which is then practiced. The teacher may read a short text to model poor and good reading (e.g. in boring, monotone and inarticulate voice versus expressive reading): what were the differences, what matters? The appropriate criteria are written on the board.
- Students then receive a text (individually, in pairs or groups of three), or they may select a text themselves. The students practice reading it expressively. Depending on the nature of the text, students may articulate certain roles, or they make take turns reading. (See also the helpful suggestions to reading aloud on page 38).
- After sufficient practice in expressive reading, an audio document can be made. Recordings can be made by cell phone, computer, dictation device, tape recorder, etc. It is essential that a good sound quality is achieved (sound test!).
- The finished sound documents may be played back to the classes. The recordings can and should be available for checking out and listening at home or during free reading sequences. Electronic files such as MP3s or CDs may also be made accessible to other people or classes.

Remarks:

- Important: never read aloud without prior reading practice. This oral reading practice lends itself well as a homework assignment, provided that students know exactly how and what to practice.
- Particularly suitable materials for this purpose include: shorter textual units (short stories, jokes, episodes, poems, dialogs). It may even be feasible to record a whole, but rather short book. See also instructional suggestion 1.
- The recordings can be enhanced through sound effects - music, etc, of various complexity all the way to creating a short radio play. As this will likely exceed the available HLT time budget, a lot of this work would have to be assigned as homework.
- The students must know from the beginning that an appealing product will be created (CD, collection of audiofiles, etc.). The creation of the product (CD cover) and its presentation in the internet or at parents’ events, could be additional elements of this project.
- This project is also well suitable for a collaboration with regular classroom instruction. This could involve bilingual or multilingual audio recordings, etc.
- Certain texts could also be presented live as an oral presentation to the class.

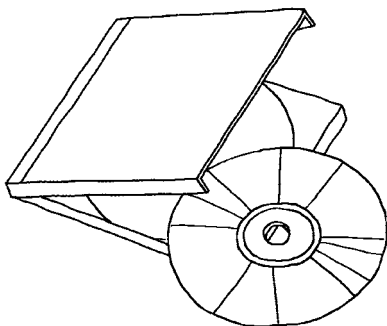

# 11

## Reading in groups or as a class

### Goal

*To share reading experiences is exciting and educational at all levels. Students can think about a collectively read text and exchange their opinions. It opens up new perspectives and presents different ways of understanding. Communal readings offer optimal and varied possibilities for follow-up discussions (see below).*

1<sup>st</sup>–9<sup>th</sup> grade

30–90 minutes



Materials:  
Several identical books  
or texts.

Variants:  
Different texts about  
the same topic.

Procedure:

#### 1. reading phase (for methodical procedures, see below)

Variant 1: All students read the same book or text. This variant is attractive in terms of the common reading experience, but is presumed to be suitable for HLT only if the text is appropriate for all proficiency levels or if the class is not overly age- heterogeneous.

Variant 2: The students read different texts about the same topic. An overarching theme in terms of the common reading experience might include "From the history of our country of origin", "poems", "non-fiction texts about our country", "different texts by our poet XY". The texts for these topics would have to be chosen according to age or proficiency level (e.g. three factual texts of various degrees of complexity about geography, three short stories of various lengths and complexity, etc.). The readings occur not in the class as a whole, but in three groups, according to age-, level and proficiency.

#### 2. Follow -up discussion, processing

In accordance with the chosen variant, the follow-up discussion may occur in the class as a whole (variant 1) or in the appropriate groups (variant 2). In the end, the reading experiences should be shared among all students, including the groups described in variant 2. In highly age-heterogeneous classes, younger students may profit and learn from the older ones by observing how they deal with texts and discuss what they have read.

Variants and possibilities of follow-up discussions include: talks, pro/contra discussions, role play/stage presentation, written assignments, etc.

Methodological approach: how to read?

The traditional approach to reading aloud where each child reads a sentence or several sentences in turn is obsolete and should be avoided. This method does not improve reading competence nor heighten the motivation for reading. The differences in reading speed, ways of reading and reading competence are just too great.

The following variant is recommended: for reading, divide the students in teams of two or three. In selecting the teams, make sure that the individual team members have approximately the same proficiency level.

**Before** reading, each team creates a reading plan. **After** reading, students record in a reading log how they proceeded and what they consider the most important content. See the examples for a reading plan and reading logs in the following pages.

Teams that read fast or teams that have finished reading receive additional tasks, such as follows:

- Practice reading out of a chapter until you master it flawlessly. Create a recording. This can later be made available to your classmates.
- Summarize individual chapters and present them later, e. g., in form of a role play, a drawing or graph.
- Expand your knowledge of the topic; conduct additional research about the theme or the author.

---

Comments:

- The motivation for reading grows if students have a voice in the selection of the material. To this end, various texts or books should be made available (2-4 for each age- or proficiency level), to ensure that students have a real choice.
- It is imperative that reading in groups or as a class is practiced again and again, as it represents a good complement to and a change from the free reading sequences (see teaching suggestions #9).

---

### Examples, reading plan, reading log:

These examples are only suggestions and can of course be modified. For the German language HLT, for example, the wording of the reading plan could be customized so as to reflect the familiar „you“ (Du) address (second person singular as opposed to the second plural form (Ihr); which would be more appropriately used for individual readings\* (Not applicable for English language version)

<b>Reading plan of the team:</b> _____	
Before you begin with reading, it is useful to plan the amount of reading you intend to cover and the time allocated for it.	
Record in the chart:	
Which chapter do you read? At what time will you have read this chapter?	
Chapter	Time frame
_____	_____
_____	_____
_____	_____
Date: _____	
Instructor's Signature: _____	
Team Signature: _____	

**Reading log of the team:** \_\_\_\_\_

Following the readings, please always consider how you performed in the readings and if the planning (reading plan) was adequate. Please fill out the following assessment:

**How we read**

- We read silently (everyone for him/herself).
- \_\_\_\_\_ ...read to us.
- We got as far as we had planned.
- We read up to page \_\_\_\_\_ .
- We are at different stages in the readings. But all of us know the story at least up to page \_\_\_\_\_ .

**What we have read:** \_\_\_\_\_

This character, action or fact has impressed us particularly:

\_\_\_\_\_

Please describe in 2–3 sentences, why this person, action or fact impressed you!

\_\_\_\_\_

\_\_\_\_\_

For me, these are the most important passages from the readings:

\_\_\_\_\_

\_\_\_\_\_

\_\_\_\_\_

**Example of a reading log (1st and 2nd grade)**





**Book titel:** \_\_\_\_\_

**Author:** \_\_\_\_\_

**Drawing:**

**Words:** \_\_\_\_\_

**I consider the book**

<b>very good</b> 	<b>good</b> 	<b>mediocre</b> 	<b>not good</b> 
---	--	--	--



# 12 Who can guess my book?

## Goal

*With this teaching idea, students learn about new books and texts and can be motivated to read. When they select and read a page aloud they must engage intensively with “their” book or text while, at the same time, they practice reading out loud, as well as intensive listening.*

1<sup>st</sup> – 9<sup>th</sup> grade

60 minutes



Materials:  
A selection of different books or other texts (picture books, dictionaries, magazines, etc.). The texts can be provided by the instructor or by the students.

### Procedure:

- Every student selects a book or a text. The other students must not see what book it is. Beginners may select a picture book. The instructor makes a list where the students “secretly” record their book title.
- The students place their book in a jacket to cover the title page.
- The students look for a passage in their book that is suitable for reading aloud to the class (the passage must be exciting or interesting; at the same time, it must not reveal just everything). The selection of an appropriate passage (ca. 1/3 – 1 page) requires an intensive examination of the text.
- Reading out loud must be practiced! The students receive ample time to practice reading aloud (preferably outside of the classroom). This can also be assigned as a homework task. The beginners who chose a picture book will be tasked to describe a chosen picture as vividly as possible.
- The students then read their selected text passages to the class (or describe the chosen picture, respectively). The listeners try to guess to which book the text passage belongs, or the genre of the book (thriller, nonfiction, fairy tale, etc.). The titles for reading aloud and guess-the-book exercises can also be distributed over 2–3 lessons.

### Remarks:

This exercise can also be organized as a little contest. The person who first guesses the correct title wins.

### Variants:

The project can be varied in many ways. Example:

- Books written in the school language could be considered as well; however, the presentation must occur in the first language.
- At the end of the year, the instructor reads to the class text passages from books that were discussed during the year. From which text where they taken?
- All title pages will be copied on a piece of paper and numbered. The students must match the passages with the title pages.
- All book titles were listed on a sheet and given to the listeners. They must now match the read out passages with the titles.
- The choice is limited to a certain type of text (fiction titles, factual texts, poems, fairy tales...).
- The students read the text passages at parents’ evenings. The parents receive a list of the books and must guess.

- The students bring their favorite books to class and read from them to the class.
- Parents, relatives, other teachers are invited to read a passage from their favorite books.

# 13 Riddle string

## Goal

*In order to collect riddles for a book or a text, the students must read the material very closely, pay attention to details and focus on key passages of the text. Solving riddles motivates in particular the younger children to read.*

2<sup>nd</sup>–9<sup>th</sup> grade

60 minutes



Materials:

Texts (not very long stories, selected articles from magazines or the internet, books, picture books for the little ones); paper strips, scissors, string.

Procedure:

- Individual work: The students select a text that interests them from a previously prepared stack of books. They read the text intently and take notes of questions which can only be answered upon fully absorbing the text content. Examples: What does the protagonist wear the first day of school after vacation? What is the name of the main character's father? In which compass direction does the river XY flow?
- The questions are written on paper strips in the sequence in which they are answered in the text. Enough space must be left for the answers after each question (either on the paper strip itself or by adding blank, colorful strips).
- The paper strips then are attached to a string. Two students each exchange their texts with the riddles on a string.



- The students read the exchanged book or the text from the others (possible as a homework assignment) and try to answer the questions on the riddle string. After reading the texts, the answers are compared.
- Those who want to solve more riddles obtain other texts and corresponding riddle strings from other students.

Remarks:

- The project “riddle string” can be extended over several weeks.
- For younger children who are not yet able to read and write well, the project can be adapted with picture books and the help of an older student who produced the riddle.
- Riddle string can easily be created by groups so that individual students only have to read part of a whole book.
- Experiences in libraries have shown that books with riddle string are much more frequently borrowed by younger children.

Variants:

The students create a riddle string for every book in their classroom library, so that at the end of the year mostly all books are furnished with such strings.

# 14

## Developing questions about texts

### Goal

*In order to compile and to solve questions about a book or a text, the text has to be closely read and understood. Most of all, creating “questions about understanding” and “questions for reflection” (see below) requires a deeper understanding of the content since the answers are not explicitly stated in the text.*

4<sup>th</sup>–9<sup>th</sup> grade

45–90 minutes



Materials:  
Books, magazines (possibly  
texts from the internet);  
notepaper.

Procedure:

- After reading a story, an article, or a whole book, the class is divided into groups of two. The group’s assignment is to develop questions about the content and the central argument of the text for the other students. Their questions should fall into the three following categories:
  - **Questions that can be looked up.** The answers to these questions are contained in the text. They are mostly clear-cut (e.g. can be answered with “correct” or “false” or with a precise indication).
  - **Questions about comprehension.** These questions can only be answered upon reflecting more deeply about the content. It requires a little “reading between the lines”. The answers to these are often not entirely unambiguous. (Example: how did the person feel? Why did s/he act in this way?)
  - **Questions for reflection.** The questions that fall into this category go beyond the content per se. Generally, there are no “correct” solutions, requiring that students discuss the responses together. (Example: what are the consequences of the end of the story? How could this conflict have been resolved in other ways?)
- Upon elaborating on the questions, the students hand them in to the teacher. The teacher then distributes the questions to the teams for answering, or the questions are discussed/resolved by the whole class.
- The differentiation between different types of questions must previously be discussed and elaborated with examples. The questions for reflection should, in any case, be discussed in the plenary, as there are often no clear answers.

Remarks:

- With mostly heterogeneous age groups in HLT, it would be preferable to conduct the exercise based on three level-appropriate different texts. It would be good if all had the same topic (although it is not critically important) e.g., fairy tales from our country of origin, life in the migration, racism, geography, etc.
- The classification of the questions into three categories derive from the educational materials “the strong language performers” and should be familiar to most students. For students with a (still) minimal language competence, the questions can be reduced to two types (questions that can be looked up and questions about comprehension).

# 15

## Creating an ad poster for a book

### Goal

*The students create an ad poster for a book that they have read. They must not only reflect upon and summarize the content, they must also conduct research about the author and the topic. At the same time, the book must be presented in a way that others become interested in the content and would want to read the book for themselves.*

1<sup>st</sup>–9<sup>th</sup> grade

60–90 minutes



Materials:

Large poster paper (size A3 or A2), coloring pencils or felt pens, glue.

Procedure:

- The project will be announced two to three weeks in advance. The students are asked to select a book for which they want to create an ad and to bring it to class. Additionally, (at least the older students) should inform themselves in libraries and bookstores about what book ads look like (e.g. posters, texts in magazines about books). Beginning students may present their favorite picture book or story book, and the teacher or an older child should assist them.
- A week before the work on the posters starts, students discuss ways to make an attractive poster ad for a book. Students will summarize and present the content of their book in an exciting and interesting way and may use graphic means to enhance the interest of the readers. Task: look for additional information about the author, and about the place and time of the action and look for appropriate illustrative materials.
- In the next sequence (lesson or double lesson), the students create an attractive poster ad for their book. They may even be able to come up with an advertising slogan for their book
- The finished posters will be displayed in a little show. Maybe the children can select the best show poster (each child may assign three points).

Remarks:

- The project is optimally suitable as a collaborative project with regular classroom instruction, be it in the context of promoting reading or a project week. It is definitely well worth to previously establish contact with the regular classroom teachers. Posters that are created within the framework of such cooperation have the advantage of being bilingual.
- If a child does not know a book in his/her native language, but has a favorite book in the language of the immigration country, s/he may describe that book – in his/her heritage language, of course!

- Many libraries are very much interested in posters or texts written by students about books. It is particularly motivating for the class if their posters are exhibited in the library.
- With the help of tablets or smartphones, older students might want to create a trailer for a book. A simple guide for it can be found under: <http://www.phlu.ch/dienstleistung/zentrum-medienbildung/medienbildung/buchtrailer>

# 16

## “Book Slam”

### Goal

*The intent of this idea is to motivate young people to read. Moreover, they learn to summarize contents as concisely as possible, and to present them in an attractive and creative fashion.*

5<sup>th</sup>–9<sup>th</sup> grade

Approx. 90 minutes



Materials:  
Different books (also non-fiction, poetry, magazines, etc.), whistle, stopwatch.

### Procedure:

- The instructor explains the terms “slam” and “book slam” (see below) two to three weeks in advance. S/he informs the class about the project and the necessary preparations:

Students must decide (alone or in groups of two) on a book (or another text, e. g. from a magazine) that they want to present. They should also think about how to create a 3-minute presentation. It should be as creative, attractive, informative and funny as possible (example: rap, recount freely, read out loud, advertising spot, etc.). Various examples can be found in the internet by googling the word “book slam”.

- Preparing and practicing the preparation (one week ahead; time requirement: one lesson).

Once the students have decided on their presentation concept, they discuss their idea with another student or team for feedback and suggestions for improvement. Important: the summary of the content must be kept to a minimum; there is no time for details. Students must think about what would be of greatest interest to the listeners and how their presentation could attract attention to them and their book.

- Implementation (time requirement: one lesson):

Each student (or team of two students) is allocated three minutes for their presentation. Two student time keepers enforce the time with a stop watch and a whistle. The public evaluates the presented texts or books by awarding points to them. They raise cards with the chosen number on a scale of 1–9; someone adds up the total and notes the result for each book or text on the board. The winner is the book or text with the most points. All books and texts will be exhibited and may be checked out by the students.

Remarks:

The rules of book slam are based on the event format of poetry slam: a very short presentation that is judged by members of the audience.

Variants:

Book slams can be optimally staged in cooperation with regular classroom instruction. That means that they will be conducted bilingually of course. Events like parents' evenings or in conjunction with partner classes are also an excellent framework for book slams.

# 17

## "Book Dating"

### Goal

*The students must summarize the content of a book or another text as succinctly as possible and present the content to the person facing them in at most four to five minutes. The other students learn about exciting books and articles from the short presentations, also receive reading recommendations and thus can be animated to read certain books or texts.*

4<sup>th</sup>–9<sup>th</sup> grade

60–90 minutes



Materials:  
various books, including non-fiction,  
books of poetry, magazines, etc.),  
stop watch.

Procedure:

- Preparation

Following the instructor's explanation of the term and the project, each student decides on a book or a text. The content is then quickly summarized (either in writing with a few keywords) as a memory aid for the presentation. A list is created as to who will present which book or text. This preparation can also be assigned as a homework assignment.

- Implementation

The class is divided into two groups. One half tells the story, the other half listens. The narrators are distributed at different tables in the room. The listeners may sit for 5 minutes at an individual narrator's table during which time text content is discussed and questions may be answered. After 5 minutes, the listeners rotate to another table. The roles are reversed in a second round, so that all students get to listen and tell a story. In a final discussion, students briefly reflect on their experiences, and the examples and quality of particularly effective presentations are discussed and commented.

Remarks:

About the term: "book dating" is a variation of the so-called "speed dating" concept. It is a method of organized partner search and dating agency, where two partners sit opposite each other for five minutes to chat about themselves. If there is mutual sympathy, the partners can meet again later. The object of book dating is to learn in five minutes as much as possible about a book, instead of a person, and to praise it, thus generating interest for it among the listeners.

# 18 Reading out loud: a self-evaluation

## Goal

*HLT students read out loud frequently from their own and other texts. However, reading aloud has to be practiced. The self-evaluation form may help students understand what they already know well and where they can improve.*

2<sup>nd</sup>–9<sup>th</sup> grade

20 minutes



Materials:  
Copies of the self-evaluation form (see below)

Procedure:

After reading aloud, students fill out a self-evaluation form. The fields in the grid can only be partially or gradually colored (from top to bottom). This self-assessment is then compared with the teacher, who suggests appropriate measures for improvement. Student who read very falteringly, should complete the exercises about reading fluency (see teaching proposal 22).

## Read out loud: grid for self-evaluation

**Paint over those fields that apply to you with a light color!**

Reading accurately		
I read individual words and simple sentences clearly and understandably.	I read short texts clearly and understandably. I rarely make reading mistakes.	I also read long and difficult texts clearly and understandably. I read flawlessly.
Reading speed / reading flow		
I already read certain passages fluently, others still haltingly.	I read mostly fluently at an even pace.	I read fluently, faster or slower, consistent with the content.
Guiding of voice / expression		
I emphasize certain words according to the content.	I change my voice often, according to the text. This way I can emphasize important passages, for example.	I can expressively emphasize and change my voice. I use pauses for special emphasis.

# 19

## Rethinking one's own reading

### Goal

The students should review their own reading behavior with the help of a questionnaire. This also provides the teacher with an insight into the students' reading habits. This is also useful as a basis for discussion with the students and it helps the instructor to better address their reading preferences in the choice of reading materials.

2<sup>nd</sup>–9<sup>th</sup> grade

20 minutes



Materials:  
Copies of the questionnaires  
(see below).

### Procedure:

Each student completes a questionnaire. The instructor collects them and provides individual feedback to the students. These discussions do not have to take place immediately and can occur little by little during HLT classroom instruction.

### Remarks:

It is useful to conduct the survey again after 6 or 12 months in order to compare the results. Has the reading behavior changed?

### Variants:

The questions have to be adapted according to age, e.g., additional questions about reading on the computer may be added for older students.

### Questionnaire about one's own reading

Page 1 of the survey:

#### 1. How I read

- I read at home every day.
- I read at home once or twice a week.
- I almost never read at home.
- I always find something that I would like to read.
- I like it when someone reads to me.
- I read at home of my own free will.
- Usually I don't read the book to the end.
- I read mostly on a screen.
- I'm always happy when I can read something new.

#### 2. What I read

*I read texts mostly in the*

- first language
- language of the school

*I love to read the most*

- thrillers
- magazines
- articles in the internet
- books where you can learn something (non-fiction)
- books or other texts about our country of origin
- adventure stories
- love stories
- football or other sports-related stories
- books that relate about earlier ages, e.g knights, Vikings
- stories about animals
- stories about horses
- comics
- something else, namely: \_\_\_\_\_



I have a favorite book or a story or a page in the internet that I find particularly interesting.  
The name of the title is:

---

---

I have a favorite character from a book or a text.  
The name of the character is:

---

---

**3. Where I read**

I like to read mostly ...  
(Example: in bed, outside, in school, etc.)

---

---

---

**4. To consider**

- I like to discuss with others what I have read.
- I am glad when others (i. e. friends) give me reading suggestions.

What is particularly important for me when I read?

---

---

---

## Part II: reading practice



# The suggestions for practice and reading skills training fall into three categories:

---

## Reading skills

Teaching proposals 20–23:

The suggestions presented here include exercise patterns which instructors may adapt according to the idiosyncracies of the first language and the specific requirements of their classes. Letters, words and short sentences should be largely automated so that the readers are able to concentrate wholly on the meaning of the text. Students who are already able to read fluently and well may forego this kind of exercise. They should receive texts and books of their choice to read during these practice exercise phases (see above #9 “free reading sequences”).

---

## Reading fluency

Teaching proposal 24:

A text can be much better understood if read at a certain speed. Experience has shown that readers not only read faster and more fluently in repeated readings, but they also comprehend the content better. The same adage applies here as well: the more automated the learning process, the more readers are able concentrate on the text content and understand it better.

Fluent reading should be practiced in many short sequences, e. g. during a period of three to four weeks for 10–15 minutes each at the beginning of class. This training to improve reading fluency can absolutely be compared with conditioning in sports or with finger exercises for playing an instrument.

---

## Reading strategies

Teaching proposals 25–27:

The third training part demonstrates how students can learn to focus on different texts and deliberately prepare themselves for reading. It provides suggestions and exercises about how to read texts, dealing with textual difficulties, and how to summarize and evaluate the materials read.

Reading strategies are to be discussed by the instructor in the classroom. Following this introduction, the strategies must be repeatedly practiced and solidified with different texts. This works best if the strategies are practiced on texts that are currently used in classroom instruction.

For additional reading strategies and information, see also “Teaching learning strategies and techniques for HLT” (volume 5 of the series „Didactic suggestions for HLT), where additional useful reading strategies are referenced in Part II and Part III.

# 20

## Recognizing letters automatically

### Goal

*Students practice their ability to recognize letters and syllables at a glance. This leads to an enhanced reading speed.*

1<sup>st</sup> – 9<sup>th</sup> grade

10–15 minutes



Materials:  
prepared worksheets  
for particular exercises,  
see below.

### Procedure:

The goal of identifying graphemes in the first language- most of those that students do not know based on their school language should be automated as much as possible and can be pursued with various exercises.

### Examples:

- Collecting letters (see exercise a; the tasks can also be modified according to needs).
- Assembling letters. Ideal for this exercise are two or three strips of paper with the alphabet legibly written on them. The strips can be placed next to each other or one on top of the other and moved about in a way that produces new combinations of letters.
- Recognize letter combinations quickly (see exercise b).
- Combining syllables (works well also with strips of paper as described above in “assembling letters”).
- Reading unusual typefaces (for this exercise, the teacher can convert a text into different font types).

### Remarks:

- The graphemes, which are not taught in regular classroom instruction, naturally play a significant role in this type of exercise. See also chapter 1a in the introduction.
- Many exercises are also suitable for working with a partner.
- Many of the required exercise sheets can also be prepared by older students for the younger ones.
- These kinds of exercises can also be used with older students if they still experience difficulties with identifying graphemes in their first language.

### Exercise a)

**How many letters M can you find?**  
**Find all letters P!**  
**Are there more or fewer than 5 letters W?**

P T U F M W H J K F M L R W D M N P Q M Z G G O  
 P H W M N W S L R J L M W N D H B W B E W M W  
 K R Ö Ü N O Y P B M W Z K P W N L R N P E R N L G  
 P A M E J L K A G T H I R W L B P M T A B P W N R  
 M S L F J P Q X Y G I D M T K T Ü W Ä A Ä Q M O D  
 G F H K R O E N W M W N V C I K T L W P N E M O  
 U T F W G Ü N O Y P B M W Z K P W N L R N P E R  
 N L G P A M E J L Ü N O L R N P E N L G P A M E J L

## Exercise b)

In the words below, look for sh, sp and th.  
Write down how many you have found.

sh ○ sp ○ th ○

shipshape, witchcraft, moonlight, distinguish, knowledge, shreds, brainstorm, glimpse, scallop, embellishment, theater, goldfish, heather, splice, zenith, sniffles, ghostly, featherweight, cyclist, diminished, smooth, rather, spinach, replenish, scholastic, duckling, scientist, industrious, puppet, thimble, uncertainty, gnash, footprint, splash, opulent, thrifty, spaceman, junction, highlight, scissors, fatherland, sprightly, snowflake, otherwise, airspeed, ghoulish, scrutiny, tarnish, shade, astonish, shocking, catlike, fishpond, throughout, shrimp, jestingly, spoilsport,..).

# 21

## Reading words faster and faster

### Goal

*The object of this exercise is quick word recognition as well the practice and expansion of frequent word images, which are identified immediately, thus eliminating the deciphering of letter by letter (sight vocabulary). This leads to an improved reading speed.*

1<sup>st</sup>–4<sup>th</sup> grade

10–15 minutes



Materials:  
appropriately prepared  
worksheets for the exercises,  
see below.

Procedure:

The goal of a mostly automatic identification of particularly frequent word images can be approached with different exercises. Examples:

- Reading words with obstacles (see exercise a below).
- Recognizing frequent mini words immediately (see exercise b below).
- Reading words with mis-aligned letters (see exercise c below).
- Finding rhyming words for frequent words (house – mouse – louse...).
- In a text taken from a newspaper article or a story, find frequently used words and highlight them in colors (e. g. "much or many", "very", "maybe", or other, frequently repeated words in this text).
- Connecting words: the students receive a worksheet with word pairs that belong together, but are written separately and jumbled up. They must connect with arrows the words that belong together (e. g. mechanic – wrench; dog – barking, etc.).

Remarks:

- Many exercises are also ideal for working in pairs.
- Many of the required worksheets for this kind of exercise can be prepared by older students for the younger ones.
- These kinds of exercises can of course also be conducted with older students if they still experience difficulties with word recognition in their first language.

## Exercise a)

**Read the sentences as accurately as possible.  
Read them several times and increase your speed.**

PonXs and h&rses d?ffer fr&m &ach other mainl% in s\*ze. Wit& a y?rdstick or a m%asuring t?pe the heXght is m5asured from the gr&und t& the hi5hest poXnt of th\* h&rses's b?ck. The size of th& h%rse 5s called fl&or hi5ht. PonXs have a fl&or hi5ht of up to one met%r 48 centimet%. H&rses a?e bigger.

---

## Exercise b)

Take a sheet of paper. Cover the text below with the paper. Now uncover the first line (only very briefly) and tell what you have read. Then, uncover the second line only very briefly and tell what you have read, and so on. Repeat this exercise several times.

**where  
by only  
that with there out  
also yet so pair**

---

## Exercise c)

**The letters are misaligned in this exercise. Read the text various times until you are able to read it accurately and fast.**

Always follow your nose

We can distinguish up to 10.000 fragrances and store in our memory. To keep odors apart is not only important to recognize dangers and distinguish for example edible from spoiled food, but our sense of smell is also closely tied to our motion life – thus we connect entirely different situations and moods with different fragrances. In order to smell things, two tiny scent molecules (molecules are tri-est of two or three atoms) which by inhaling reach the olfactory mucosa in the upper nasal cavity when inhaled with the air.

# 22

## Seeing sentences as a whole

### Goal

*This exercise ties into the suggestions 20 and 21 and continues in the areas of clauses. Recognizing, complementing and combining of frequent clauses facilitates the connection of meanings and with it, the reading process.*

1<sup>st</sup>–4<sup>th</sup> grade

10–15 minutes



Materials:  
prepared worksheets  
for the exercises,  
see below.

Procedure:

The goal of an increasingly fluent identification and interpretation of particularly frequent clauses in the first language can be approached with various exercises. Examples:

- From a dwarf sentence to a giant sentence (see exercise a below) can be best accomplished with long paper strips.
- Completing sentences (see exercise b below).
- Combining clauses: the teacher distributes sheets of paper for this exercise. The pages are divided by a line down the middle. On the left side are the sentence beginnings, and on the right side, the second half of these sentences, but in a different order. The students must draw lines to correctly combine the beginnings and the ends of the sentences that belong together. (Example: In the summer, I swim → happily in the sea).

Remarks:

- Many of these exercises lend themselves well for working in pairs.
- Many of the worksheets for these kind of exercises can be prepared by the older students for the younger ones.
- It is certainly possible to conduct these exercises with older students as well, particularly if they still experience difficulties in dealing with clauses in their first language.

### Exercise a)

**Read the following sentences several times.**

Peter sprinkles salt.

Peter sprinkles secretly salt.

Peter sprinkles secretly salt in the tea.

My brother Peter sprinkles secretly salt in the tea.

My naughty brother Peter sprinkles secretly salt in the tea.

My naughty brother Peter sprinkles secretly salt in our mother's hot tea.



## Exercise b)

**Look for the missing parts on the right; insert them into the text**

It is Friday \_\_\_\_\_ hour.                      during the last  
\_\_\_\_\_ sit in a circle.                      The children  
The teacher tells \_\_\_\_\_ .                      a story

# 23

## Understanding what I read

### Goal

*Comprehension training in terms of a sentence and/or short text.*

1<sup>st</sup>–5<sup>th</sup> grade

10–15 minutes



Materials:  
prepared worksheets  
as required for the exercises,  
see below.

Procedure:

The text comprehension on the small-scale level of an individual sentence and/or a short text can be practiced with various exercises. Examples:

- Compare texts and pictures. Students receive two sheets; the first one contains eight sentences or short texts (# 1–8), the second one eight pictures (a–h). They now have to find the attributions (e. g. “Text 1 goes with picture d”).
- Re-arrange texts (see exercise a).
- Find errors in the texts (see exercise b).
- Recognize correct and incorrect sentences. A worksheet with 20 prepared statements will be distributed (Example: “dogs can fly”. “Several languages are spoken in Turkey”). Each statement is then checked whether it is correct or false.

Remarks:

- Many exercises lend themselves well for working with a partner.
- Many of the worksheets for this type of exercise can be prepared by the older students for the younger ones.
- If needed, these kinds of exercises can of course also be conducted with older students if they still experience difficulties with reading comprehension in their first language.

## Exercise a)

**Two totally different texts got mixed up here. Take two pens or highlighters of different colors and underline the parts that belong together!**

The conquest of space is an old dream of mankind. Mick is lying awake, holding Mo in his arm. In the year 1969, three astronauts lift-off in America. They fly to the moon with a rocket. Mo is sleeping deeply. Mo is Mick's stuffed gorilla. Mick takes him along wherever he goes. Neil Armstrong steps as first man on the moon. Only not to school. Teachers don't like gorillas. The astronauts carry moon rocks back to earth.

## Exercise b)

**Here 7 errors have snuck in. Highlight them!**

Stewed apples

Ingredients:

6 tart apples, sugar, cinnamon, very little water

This is how it is done:

Take the bananas, peel them and cut them into pieces. Now take a book and add very little water. Place the pan on the washing machine and add the apples together with about 3 table spoons of salt. Now you have to let the whole thing sleep for about 8–10 minutes at medium heat and stir to keep it from burning. When the apple pieces are green, the stew is done. Now you can add a little gasoline.

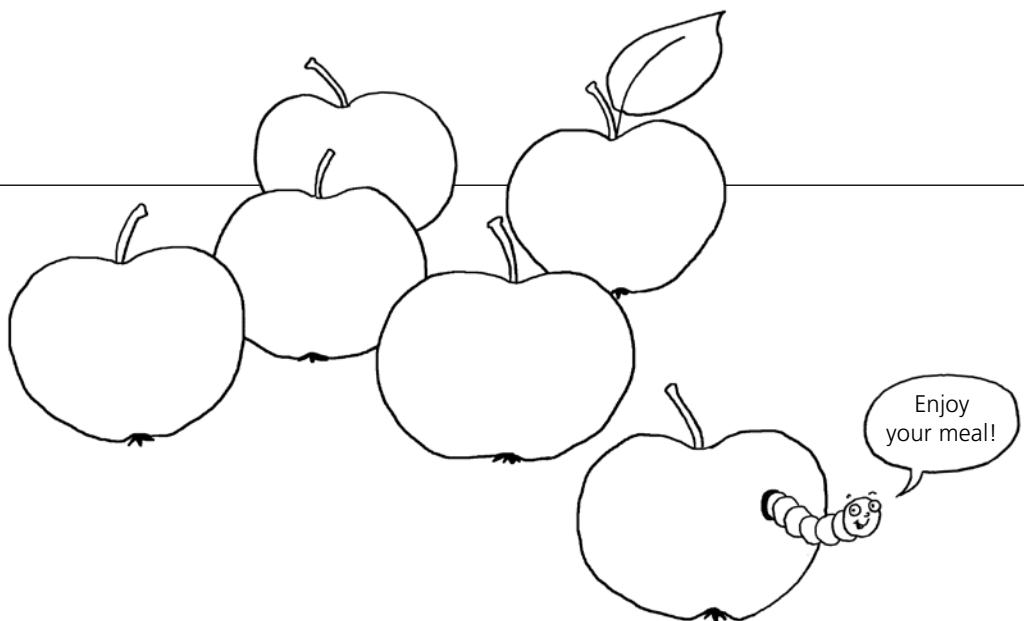

## 24

## Practicing reading fluency

## Goal

*The goal of reading fluency is improving reading competence. There is no doubt as to the direct relationship between fluency (the ability to read fluently and accurately) and reading competence. It is important to administer these exercises over a prolonged time (in HLT for at least 4-6 weeks), whereby 10–15 minutes per training session should suffice. The time invested here is well worth the effort, particularly since the progress in reading becomes immediately apparent to the students, which generally also leads to an improved self concept. In light of the HLT classes' inherent heterogeneousness in terms of age and proficiency, the training texts must be prepared for at least three levels.*

1<sup>st</sup>–9<sup>th</sup> grade

10–15 minutes



## Materials:

Prepared texts for different age and competence levels; worksheets for reading and control with questions for self-assessment, reading time and feedback (see texts and extent below).

## Procedure:

- Prior to the training period of several weeks, the instructor informs the students about the goal and purpose of this training. S/he may certainly want to suggest at the same time that reading training in the first language also benefits reading in regular classroom instruction. In this introductory phase, experiences and techniques should be identified which students may already be aware of from their regular classes.

## Suggestions about the concrete implementation:

- It is important to give students precise instructions prior to the exercises so that they are able to conduct the training as independently as possible. This affords the instructor time to observe individual students more closely, and to accompany and advise them.
- Concentrated listening in this part of training is equally important as good reading. Concentrated listening should also be explained to the students and practiced prior to the training (someone reads out loud and the others mark the reading mistakes).
- Reading fluency is practiced in tandem. Tandems are comprised of two students of the same level and age group. The difference in reading competences between them should not be too great.
- Attention is paid to accuracy of reading and reading speed. For this purpose, a stop watch may also be used (for target times, see below).
- Depending on the age of the students and the intensity of the training, the focus on specific aspects and potential mistakes will be determined:
  - Reading flow (stagnations)
  - Reading accuracy (slips of the tongue, omissions, misread words, etc.)
  - Reading clarity (swallowing syllables, appropriate volume, etc.)
  - Reading expression (monotonous reading, droning, etc.)

- Each tandem now receives one text, once as a reading sheet, once as a control sheet (see examples on the following pages). Texts will have to be prepared for different proficiency levels to allow for appropriate training opportunities for all age and proficiency levels. Tandem members agree who reads first (s1) and who listens (s2)
- S1 reads the text out loud for the first time and answers the questions at the bottom of the sheet (evaluation of difficulty “for next time, I intend to”). S2 clocks the time which s1 took to read the text, records it in the control sheet, and provides feedback (“My tip for you”).
- S1 reads the text a second time and then a third time. Each round includes self-evaluation and feedback, measuring and recording time, as described above.
- Role reversal; now s2 reads the same text (or a different text from the same proficiency level) three times, s1 measures the time and provides feedback.
- The control sheets are collected. This kind of regular recordings by the listeners provide sort of a read-out diary, which documents progress.
- Periodically there should be a short class discussion: what kinds of progress have you achieved, what have you noticed, etc.

---

Remarks:

- Under no circumstances should the purpose of training be sort of a contest to see who reads the texts as fast as possible. For this purpose, age-appropriate and level-specific target times are provided. For beginning readers, these should be about 65 words per minute; for more advanced students about 100 words per minute, and for accomplished readers about 130 words per minute.
- About text length: the texts should be readable in about 90 seconds. This translates into approximately 100 words for level 1, approx. 150 words for level 2, and about 200 words for level 3.
- Every reading and control sheet must contain the questions about self-assessment and measuring time, respectively, as well as “my tip for you”, as seen in the examples on the following page.
- In terms of efficiency and sustainability, it would be optimal if the training in reading fluency in HLT could be coordinated with regular classroom instruction (or at least with a few regular classroom teachers). It is certainly well worth finding out from regular teachers and their language teaching materials what kinds of applicable examples and exercises the students already know from their regular classes.
- It is useful to record the readings from time to time on a recording device. In the course of the training program there emerges sort of a read-out biography: the readers can listen to their progress by way of the sequential recordings, as well as see it from the declining number of recorded error markings in the protocols.

## Sample reading sheet

(middle level, 156 words)

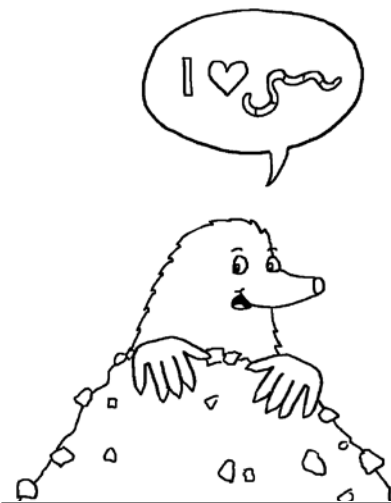

### Moles

Moles live underground. They grow to about 12 cm in length. Moles have incredibly poor vision. Their little beady eyes can only distinguish between light and dark. They do not need them for anything else, after all they live underground. Moles have a poorly developed sense of hearing. In exchange, they can "hear" with their hairs. Moles can perceive the slightest vibrations, oscillations, movements and even changes in air pressure with their hairs. Thus they are always on the spot if an earthworm drops with a thud into one of their subterranean paths. The Moles live and work in shifts: they dig, hunt and eat for four hours. Then they sleep for four hours. Each shift thus repeats itself three times a day. Moles dig complex tunnel systems that can extend for 200 meters and lie up to 70cm below the surface. Aside from a "bedroom" they also establish for themselves a nesting room and a pantry. However, the tunnels are for the most part nothing but "earthworm traps".

For me, reading this text was:

- easy
- rather easy
- rather difficult
- difficult

For next time, I intend to:

- I try to read more accurately.
- I try to read more fluently.
- I read equally well again.
- I...

## Sample control sheet

### Moles

Moles live underground. They grow to about 12 cm in length. Moles have incredibly poor vision. Their little beady eyes can only distinguish between light and dark. They do not need them for anything else, after all they live underground. Moles have a poorly developed sense of hearing. In exchange, they can "hear" with their hairs. Moles can perceive the slightest vibrations, oscillations, movements and even changes in air pressure with their hairs. Thus they are always on the spot if an earthworm drops with a thud into one of their subterranean paths. The Moles live and work in shifts: they dig, hunt and eat for four hours. Then they sleep for four hours. Each shift thus repeats itself three times a day. Moles dig complex tunnel systems that can extend for 200 meters and lie up to 70cm below the surface. Aside from a "bedroom" they also establish for themselves a nesting room and a pantry. However, the tunnels are for the most part nothing but "earthworm traps".

(156 words, target time 1 minute 30 seconds)

Reading time: 1. reading \_\_\_\_\_ minutes \_\_\_\_\_ seconds

Reading time: 2. reading \_\_\_\_\_ minutes \_\_\_\_\_ seconds

Reading time: 3. reading \_\_\_\_\_ minutes \_\_\_\_\_ seconds

My tip for you:

- Try to read more accurately.
- Try to read more fluently.
- Read again equally well..
- Something else...

# 25 Strategies before reading

## Goal

*When the readers know how to prepare themselves for an upcoming reading assignment, the probability is higher that their reading comprehension process in fact improves. This exercise provides students with a useful strategy for this purpose.*

3<sup>rd</sup>–9<sup>th</sup> grade

30 minutes



Materials:  
current texts from classroom instruction, short stories, non-fiction, books, magazines. The materials must be prepared for 3 different age and proficiency levels.

Procedure:

- Introduction, preliminary information: the teacher demonstrates a specific example of how to assess and get to know a text in three steps prior to reading it. Questions posed to the text include, for example:
  - What do I expect from this text; which reading strategy is useful (should I skim through the text; do I have to know every little detail; am I just looking for certain information)?
  - Which genre/kind of text does it belong to?
  - How difficult is the text; what difficulties should be anticipated and where, and what should I do to overcome them?
  - Do I need previous knowledge to understand this text?
- For this assignment and all subsequent exercises, the following steps apply, which students also receive in writing or copy from the board:
  - **Recognize theme and text type:** discern textual characteristics (pictures, charts, titles, etc.).
  - **Activate previous knowledge:** make notes of key words to the topic, formulate assumptions and questions about text content.
  - **Take a reading sample:** closely read a few sentences, consider how to best read the whole text and estimate the time required for it.
- The students receive differentiated texts (according to age and proficiency level) and follow the above referenced three steps. This can occur individually or by working with a partner.
- Concluding with a short exchange of experiences with this procedure.

Remarks:

- Exercises of this kind should of course be conducted repeatedly and with different texts. It would be best if these reading strategies could be practiced with actual texts from the classroom.
- The exercises 25–27 are closely connected and therefore should be presented to and practiced with the students as such.
- The steps described above, together with steps # 26 and 27, can also be summarized on a worksheet with the title “reading strategies”.

# 26

## Strategies during reading

### Goal

To increase their reading competence, students should first learn and practice how to deliberately and purposefully deal with “difficult” words or text passages. Secondly, their awareness of the central or key ideas of a text should be raised (what are the main issues, what are the key statements in the text?).

3<sup>rd</sup>–9<sup>th</sup> grade

30 minutes



#### Materials:

Actual texts from the classroom, short stories, non-fiction, books, magazines. Materials must be prepared for 2–3 different age and competence levels.

#### Procedure:

- The instructors demonstrate with one or several examples how to master textual difficulties and how to recognize main statements. This works best if the teacher models the corresponding steps and “thinks out loud” in doing so.
- Central to this process are the following two steps, which the students receive in writing or copy from the board:
  - **Recognize difficult passages**, clarify and comprehend: initial reading, repeated reading, searching individually for explanations in the text, encyclopedias, dictionaries, and using internet.
  - **Recognize key statements**: divide the text into logical segments, formulate headings, take notes of key terms.



- Once the procedure is understood by all, the students receive different texts (age appropriate and differentiated for proficiency level) and practice dealing with difficulties and recognizing key statements of a text on their own in accordance with the above two points. This can be done individually or in pairs.
- Concluding with a brief review and an exchange of experiences with this approach.

Remarks:

- Exercises of this kind should, of course, be conducted repeatedly and with different reading materials, ideally with current texts from regular classroom instruction.
- Exercises # 25–27 are closely related and should be presented to and practiced with the students in this context.
- The above referenced steps can be summarized with the steps in #25 and 27 in a worksheet under the heading “reading strategies”.
- Strategies and suggestions for comprehension of key statements can also be found in volume 5 “Teaching of learning strategies and techniques in HLT” (book 5 of the series “Didactic suggestions for HLT”); see #9 “Marking the most important things in the texts”.

# 27 Strategies after reading

## Goal

*First, the students should learn how to summarize a text after reading it. There are various useful approaches, depending on the text type. Secondly, they should learn and practice how to independently form an opinion and to explain and justify it.*

3<sup>rd</sup>–9<sup>th</sup> grade

30 minutes



Materials:

Current texts from classroom instruction, short stories, non-fiction, books and magazines. Materials must be prepared for 2–3 different age and proficiency levels.

Procedure:

- The teacher explains and demonstrates how to summarize content in various ways. This will be practiced with different texts (texts of 2–3 different levels, and 2–3 different kinds, e. g. non-fiction, history, etc.). The class as a whole then practices formulating opinions about texts and defending them on their own.
- The following steps apply for the exercise below, which the students receive in writing or copy from the board, once the procedure is understood by all:
  - **Summarizing content:** different forms are useful, depending on the text, e. g. chart, chronological lists/time line, role play, re-narration, graphic depictions, etc.
  - **Judging a text:** after reading, questions, such as follows, should be answered and discussed: How did you like the text? What did you find interesting, what was new for you? What is your opinion about the meaning? To whom can you recommend the text?
- When all students understand the approach, they receive various texts (appropriate for their age and proficiency level). They practice summarizing and formulating opinions independently according to the above referenced points, either independently or in pairs.



Remarks:

- Exercises of this kind should, of course, be conducted repeatedly and with different reading materials. Ideally, training would occur with current texts from regular classroom instruction.
- Exercises # 25–27 are closely related and should be presented to and practiced with the students in this context.
- The above referenced steps can be summarized with the steps in #25 and 26 on a worksheet under the heading “reading strategies”.
- Strategies and suggestions for creating summaries can also be found in volume 5 “Teaching of learning strategies and techniques in HLT” (book 5 of the series “Didactic suggestions for HLT”); see #10 “Creating good summaries”.

**Part III:  
literary-cultural  
education**



# There are numerous ways of promoting literary comprehension in the classroom.

---

## Teaching suggestions 28–30

An important goal of native language education is to get students to appreciate the beauty of their native language and to introduce them to the cultural diversity of their country and its literary manifestations – fairy tales, narratives, stories, poetry, etc. Each country, each culture has its own unique stories, a rich treasure in fables, fairy tales and traditional stories.

Many students will need additional help in order to imagine the contents of the texts. This pertains mostly to two groups of students: those from educationally disadvantaged families who have no access to literature at home, and those who are not so familiar with their country of origin and perhaps only spend their vacations there. Not only are they often unfamiliar with the locations of the action, but have no connection with the legends and heroes (the legendary character Rozafa is known to every child in Albania, but not to those in the Albanian migration). Moreover, there are frequently value differences between the countries of origin and the host countries, as the literature there is based partly on different norms and traditions, and refers back to a different distribution of roles, rituals and behaviors. This can also lead to frustrations and comprehension problems.

The following examples demonstrate how HLT instructors can facilitate their students' experiences with literary, i. e. linguistically designed texts, and how to practice the comprehension of literary texts with different assignments.



# 28

## Listening

### Goal

*The students should have an opportunity to sensually experience and appreciate the beauty of their native language. This listening experience should sensitize them to the sound, rhythm and the melody and the aesthetics of creatively designed language. Poems serve well as a basis for this listening experience, such as those that can be found on the internet platform [www.lyrikline.org](http://www.lyrikline.org) (see below).*

5<sup>th</sup> – 9<sup>th</sup> grade

30–45 minutes



Materials:  
Access to internet and a printer,  
if possible.



### Procedure:

- Variants with access to the internet platform [www.lyrikline.org](http://www.lyrikline.org):  
The teacher introduces the internet page. Students then form teams of two. They are to find on this platform a poem of their liking in their native language. They then have to present the poem to the class and should respond to the following questions:
  - How can you tell that this is a poem?
  - What is the main theme of the poem?
  - Which words or sentences sound particularly beautiful?
  - What is the prevailing mood in this poem?
  - Which colors or what kind of music are appropriate for this poem?
  - To whom might the poem appeal particularly?
- If the HLT has no access to computers, this research can be assigned as a homework task. The recording of the poem should be brought to class as an audio file (i.e. on a handheld device).
- Instead of using [www.lyrikonline.org](http://www.lyrikonline.org) or in addition to that resource, listening can also be trained with other texts and readers: children's lyrics, short stories, jokes, etc., read by the teacher, by parents, or students (after intensive preparation) and recorded in order to assemble a collection of audio files (see also instructional suggestions 10, Reading aloud and recording for others).

Remarks:

- Concerning the lyric platform [www.lyrikline.org](http://www.lyrikline.org): this website is a true treasure trove! It has poems in more than 60 languages, read aloud by the authors themselves and supplemented with biographical information about them. Frequently, there is also a translation into German or the other languages which the website can accommodate. About operating the website: select first the language for navigating the site, then enter the name of the desired language of the poems into the field "search term".

Variants:

There are many possible expansion possibilities, i.e.:

- The texts (frequently with translation) can also be printed out and copied, which also allows for language comparisons and language observations.
- The students practice reading their favorite poem and recite it themselves to the class.
- The students also listen to poems in other languages, decide on a particularly beautiful listening experience and/or make comparisons with their own language (sound, speech rhythm, melody, tempo, etc.).

# 29 Characters in a book

## Goal

*In the course of reading the text, the students create a portrait of the protagonist or another important figure, and make a deeper analysis of that which this character experiences. This deeper understanding and identification is crucial for the students' comprehension of the plot and the relationships between the characters.*

5<sup>th</sup>–9<sup>th</sup> grade

Approx. 90 minutes



Materials:

History, story, or an entire book (also a picture book), paper, coloring pencils.

Procedure:

- During or after reading a story or a book (also a story book or picture book), the students create a portrait or a profile of the protagonist or several important figures. This can be accomplished as an individual assignment or with a partner. Prior to the assignment, some of the salient points for such a portrait or profile are discussed; e.g.
  - Where does the person live?
  - What does the person look like?
  - What can this person do particularly well, and what not?
  - What worries this person?
  - What do you know about this person's family?
  - Which other figures are important for this person?
  - Would you like to be friends with this person, and if yes, why? If no, why not?



- Besides the written responses, the portrait should also include a drawing of the person.
- These portraits are then discussed and compared, first in groups, then in the class as a whole.

**What does this person think?**

(Thoughts can be found often between the lines).

---



---



---



---



---



**What does the person do in this story?**

(mostly stated in the text)

---



---



---



---



---

Remarks:

The project can, of course, be conducted as well with students in grades 7–9. The assignments can become easier or more challenging, depending on the figure, the language and the course of action.

# 30

## Figuratively envisioning a place

### Goal

*This exercise should evoke the students' internal perception and imagination of a plot or mood. The readers' internal perception is an important element in terms of understanding a text. At the same time, many students have difficulties imagining places, people, or moods if they do not receive already completed pictures of them.*

1<sup>st</sup>–9<sup>th</sup> grade

45 minutes



Materials:  
Story or a narrative  
(if possible 2–3 texts  
for various levels).

### Procedure:

- The teacher reads a story to the class. This can involve the entire class, if a story is appropriate for all age-levels, otherwise it requires different age-specific stories.
- The class as a whole (or in different age and competence levels) summarizes the content, and questions about understanding are clarified. With complex texts, a copy may be provided beforehand so that students can recap the content once more for themselves.
- With their eyes closed, the students have to imagine an important place of action in this story, as if it were a film. Questions like the following (in this case involving a room in a story that was read to them) may help in this imagination process:
  - Are there windows?
  - Where is the door located?
  - What kind of furniture is there?
  - Is the room dark, is the light on, or is there daylight in the room?
  - Are there pictures on the walls?
  - How do you feel when you're in this room; why?
- After a few minutes when all students should have completed their internal pictures, the students draw a plan of the room or describe in writing how they imagine this room, or how they would feel being in this room.
- The students then seek out a partner to discuss their results and receive additional time to review their assignments and clarify ambiguities, if needed.
- Finally, the texts and drawings are compared and discussed by the class as a whole.

### Variants:

- The exercise should be repeated various times.
- It can also be adapted and modified in terms of moods and emotions or the persons involved (instead of just the room).





# Bibliography

- Bertschi-Kaufmann, Andrea (eds.) (2007): Lesekompetenz – Leseleistung – Leseförderung. Grundlagen, Modelle und Materialsien. Seelze- Velber und Zug: Kallmeyer & Klett und Balmer.
- Bibliomedia, QUIIMS (2005): Sprachenvielfalt in Schule und Bibliothek, Solothurn: Bibliomedia.
- Kruse, Gerd; Maria Riss; Ursula Rickli; Thomas Sommer (2010): Lesen. Das Training 1. Bern: Schulverlag plus.
- Kruse, Gerd; Maria Riss; Thomas Sommer (2012): Lesen. Das Training 2. Bern: Schulverlag plus.
- Kruse, Gerd; Maria Riss; Thomas Sommer (2013): Lesen. Das Training 3. Bern: Schulverlag plus.
- Isler, Dieter (2005): Schule und Bibliothek – Zusammenarbeit vor Ort. In: Leseforum 14/2005, p. 51– 53. Link: [www.leseforum.ch/myUploadData/files/14\\_Bulletin\\_2005.pdf](http://www.leseforum.ch/myUploadData/files/14_Bulletin_2005.pdf)
- Riss, Maria (2012): Alles und Nichts. Didaktischer Kommentar. Bern: Schulverlag plus.
- Rosebrock, Cornelia et al. (2011): Leseflüssigkeit fördern. Lautleseverfahren für die Primar- und Sekundarstufe. Seelze: Kallmeyer & Klett.
- Rosebrock, Cornelia; Daniel Nix (2008): Grundlagen der Lesedidaktik und der systematischen schulischen Leseförderung. Baltmannsweiler: Schneider Hohengehren.
- Spinner, Kaspar (2007): Lesen als ästhetische Bildung. In: Andrea Bertschi-Kaufmann (eds.): Lesekompetenz – Leseleistung – Leseförderung. Seelze-Velber und Zug: Kallmeyer & Klett und Balmer, p. 83–94.
- Sträuli, Barbara et al. (2005): Leseknick – Lesekick. Leseförderung in vielsprachigen Schulen. Zürich: Lehrmittelverlag des Kantons Zürich.

The series “Materials for heritage language teaching” is comprised of six volumes, designed to enhance the quality of heritage language teaching (HSU, in Switzerland: HSK) and to improve its cross-linking with regular classroom education.

The publications address the specific needs of future and current heritage language teachers as well as their support institutions in the countries of origin and in the immigration countries. The foundation text (Handbook and workbook: Foundations and backgrounds) includes, among other things, key aspects of current pedagogy, didactics and methodology in the Western and North European countries.

The workbooks provide teaching suggestions and offer specific prompts and planning models for various instructional areas (promotion of writing in the heritage language, etc.). The publications were created in close collaboration with practicing HSU instructors in order to ensure the practical relevance and application of the didactic suggestions from the beginning.

The series includes the following publications:



The publications “Materials for heritage language teaching” have been released in German, English, Albanian, Bosnian/Croatian/Serbian, Portuguese and Turkish. They are published by the Center for International Projects in Education (IPE) of the Zurich University of Teacher Education.