

# Teaching learning strategies and techniques



Materials for heritage language teaching

**Didactic suggestions**

**5**

# Teaching learning strategies and techniques

Basil Schader

Valeria Bovina

Materials for heritage language teaching

**Didactic suggestions**

**5**

---

Series "Materials for heritage language teaching"  
(HLT; in Switzerland HSK: Instruction in native language and culture); Didactic suggestions 5.

Published by the Center for IPE (International Projects in Education) Zurich University of Teacher Education.



---

Project leader/editor: Basil Schader

---

Author: Basil Schader, Prof. Dr. Dr., Language didactics, PH Zürich, expert for intercultural didactics, author of teaching materials

---

Editorial support for HLT: Valeria Bovina, instructor of Italian, HSU Zürich.

---

Test-teaching trials: Nexhat Maloku, Zürich (HSK Albanian)  
Hüsniye Göktaş, Zürich (HSK Turkish)  
Dragana Dimitrijević, Zürich (HSK Serbian)  
Elisa Aeschmann-Ferreira and  
Raquel Rocha (HSK Portuguese)  
Hazir Mehmeti, Vienna  
Rifat Hamiti, Düsseldorf

---

Illustrations, overall visual concept and realization: Barbara Müller, Erlenbach

---

Translator: Alfred Keller, Tamarac

---

Printing:.

---

The series "Materials for heritage language teaching" was made possible with the support of the Swiss Federal Office of Culture (BAK).



Schweizerische Eidgenossenschaft  
Confédération suisse  
Confederazione Svizzera  
Confederaziun svizra

Eidgenössisches Departement des Innern EDI  
Bundesamt für Kultur BAK

---

This project was partially financed with the support of the European Commission.  
The responsibility for the content of this publication rests solely with the authors: the Commission has no responsibility for the further use of the information contained herein.



Lifelong  
Learning  
Programme

---

# Table of contents\*

<b>Preface to the series “Materials for heritage language teaching”</b>	5
---	---

---

## **Introduction**

<b>1. Goals and structure of this volume</b>	7
<b>2. About the importance of learning strategies and techniques</b>	7
<b>3. The role of HLT in mediating learning strategies</b>	8
<b>4. About the 10-step training program in Part II</b>	10

---

Bibliography	11
--------------	----

---

## **I Part I: learning strategies and techniques for different sub-areas**

<b>1. Techniques and strategies for practicing in general (M 1–4)</b>	14
---	----

---

M1 Practicing and training – reasons and a few hot tips

---

M2 Understanding and rendering of content

---

M3 Creating one’s own training aids

---

M4 Flashcards: a useful aid for learning professionals

---

<b>2. Techniques and strategies for using learning tools (dictionaries, encyclopedias, internet) (M 5–7)</b>	21
--	----

---

M5 Locating something quickly in a dictionary or in an encyclopedia

---

M6 Finding your way around books

---

M7 Obtaining information from the internet and elsewhere

---

<b>3. Techniques and strategies for reading (M 8–10)</b>	27
--	----

---

M8 Understanding the precise meaning of a text with the 5-step technique

---

M9 Highlighting essential information; taking notes

---

\* Notice: the pages with materials for the students and the 10-step program do not have page numbers. Since these materials are handed out separately, page numbers would not make sense to the students. The pages with materials are marked M1–M15 and S1–S10b, respectively.

---

M10 Creating good summaries

---

**4. Techniques and strategies for writing (M11–13)** 34

---

M11 Finding ideas, text planning with clusters, mind maps and little notes

---

M12 Planning, writing and revising a text – step by step

---

M13 Addressing writing problems

---

**5. Techniques and strategies for the preparation of presentations and tests (M 14–15)** 41

---

M14 Preparing and delivering a presentation

---

M15 Preparing yourself for a test: tips and techniques

---

**II Part II: the 10-step training program for successful learning**

47

S1 Step 1: adequate sleep and exercise

---

S2 Step 2: healthy eating, wholesome breakfast

---

S3 Step 3: your workplace at home

---

S4 Step 4: a quiet workplace

---

S5 Step 5: fixed working hours

---

S6 Step 6: planning the work:  
a) making a plan

---

S7 Step 7: planning the work:  
b) setting goals and subgoals

---

S8 Step 8: beginning the work

---

S9 Step 9: working in a concentrated manner, taking breaks

---

S10 Step 10: and if once you absolutely don't feel like ...

---

# Preface to the series “Materials for heritage language teaching”

Heritage language teaching (HLT), or mother-tongue teaching, known mostly as “Herkunftssprachlicher Unterricht (HSU)” in Germany and Austria and “Unterricht in Heimatlicher Sprache und Kultur (HSK)” in Switzerland, plays an important role in the development of a child’s identity and language. It promotes multilingualism and serves as a valuable personal and social resource. The awareness of this fact has long been borne out by research and framework guidelines, such as the recommendations of the Council of Europe R(82)18 and R(98)6. Nevertheless, this kind of instruction for the most part still takes place under more difficult conditions than regular curriculum classes. Various factors are responsible:

- Heritage language education is on an insecure footing institutionally and financially in many places. In Switzerland, for instance, heritage language teachers almost everywhere are paid by the country of origin or even the parents.
- Heritage language classes are often poorly coordinated with regular classroom instruction; contact and cooperation with regular curriculum teaching staff is often very poorly developed.
- Heritage language classes often occur only two hours per week, which makes constructive, uninterrupted learning more difficult.
- Heritage language classes are mostly optional, and the commitment on the part of the students is not very strong.
- Heritage language classes involve multiclass teaching as a rule, with students from the 1st to the 9th grade joined into a single class. This requires a great deal of internal differentiation and didactical skill on the part of the instructor.
- The heterogeneity of the student body in heritage language classrooms is extremely high in terms of the students’ linguistic competence as well. While some have acquired at home good proficiency in both dialect and standard use of their native language, others may speak only dialect. For second or third generation heritage speakers who have already resided for many years in the new country, the language spoken there (e.g. German) has become the dominant language, while their command of the first language is limited to dialect, transmitted exclusively orally, and with a vocabulary reduced to familiar issues.

- The heritage language instructors have generally received a good basic education in their countries of origin, but they are not at all prepared for the realities and the challenges of teaching in a multiclass environment in the migration destination countries. Professional development opportunities in the host countries exist for the most part only to an insufficient extent.

The series “Materials for heritage language teaching” supports the teachers of native language education classes in their important and demanding task and thereby hopes to contribute to the optimal quality of this kind of learning. The review of the backgrounds and principles of the current pedagogy and didactics in western and northern European immigration countries (c.f. the volume Foundations...) furthers this goal, supported with concrete practical suggestions and models for the classroom in the workbooks “didactic suggestions”. Their main emphasis is the promotion of linguistic competence. The didactical suggestions purposely revert to the pedagogical principles and procedures that are familiar to the students from the regular curriculum and its teaching materials. This familiarity brings heritage language education and regular curriculum instruction in close contact and ensures the greatest possible coherence between the two. As the teachers of the heritage language education programs familiarize themselves with the didactic approaches and specific proceedings that are currently used in the regular curricula, they receive further training and, it is hoped, a strengthening of their stature as partners of equal value in the educational process of the students who are growing up bilingually and bi-culturally.

The series “Materials for heritage language teaching” is published by the Center for International Projects in Education (IPE) at the Zurich University of Teacher Education. It is developed in close collaboration between Swiss and other West European specialists on the one hand, as well as experts and practicing instructors of heritage language programs. This ensures that the offered information and suggestions reflect the real circumstances, needs and possibilities of heritage language programs and meet the objective of functionality and practicality.



# Introduction

## 1. Goals and structure of this volume

The objectives of the present volume are the same as those of the foundations handbook and the didactic suggestions in booklets 1–4: supporting the HLT instructors in shaping a classroom experience that is current and attractive and methodologically and didactically as compatible as possible with regular classroom education in the immigration country.

However, the structure and the content concept of the volume “Teaching learning strategies and techniques in HLT” differs from volumes 1–4. Whereas the suggestions and teaching proposals there were primarily intended for the instructors, volume 5 is mainly comprised of teaching materials for students from the 4th or 5th grade on. The materials would need to be tweaked and simplified to be age-appropriate for the younger students.

### Part I

Part I is comprised of 15 pages (M1–15) with a selection of concrete, easily understandable instructions for learning strategies and techniques. They concern the topics of practicing in general, using study tools, reading comprehension, writing, as well as test preparation and preparing for presentations. These pages are conceived as master copies and will be distributed to the students as copies. There is no particular sequential order, which allows the choice of materials to better support the current theme or kind of learning situation. For each learning technique, i.e., materials M1–15, there are recommendations for didactical implementation. These can be found on the introduction pages of the five mentioned theme areas and offer the instructors hints and suggestions for the specific tasks. (It should be noted that, naturally, the workbooks 1–4 already point out hints for learning strategies, see for example the writing strategies in volume 1. The prompts there, however, are directed at the instructors, whereas volume 5 offers materials that are directly intended for the students.

### Part II

Part II contains a training program aimed at the prerequisites for successful learning and student success. The focus of this program – which is further described in chapter 4 below – is on the “unwritten rules” and their importance, particularly since complying with rules can be crucial or decisive for student success in the middle and northern European immigration countries. If we succeed in acquainting HLT students with these rules and work techniques and how they themselves can apply and use them, it would be an important step toward equal opportunity.

### Initial introduction

Preceding the two practice parts is an introduction to the learning techniques and strategies in general (chapter 2), suggestions about the role of HLT in mediating these techniques (chapter 3), and suggestions for working with the referenced training program in Part II (chapter 4).

### Regarding the origin of ideas

The current volume is closely oriented to, in part verbatim, the following titles by the same author and publisher: Basil Schader (2012, 2013): *Mein schlaues Lernheft*. Zürich, Orell Füssli. (My clever textbook). The “clever textbook” has not only proven its worth in Switzerland, it was also published in two Albanian editions (Peja, 2012; Lausanne, 2013). The author’s assembled learning techniques in those issues were partially shortened or summarized for inclusion in the present publication; the training program component was wholly integrated, however. The introduction, as well as the didactic suggestions and parts of the graphic design are totally new.

---

## 2. About the importance of learning strategies and techniques

What becomes immediately apparent in looking through current teaching materials – particularly language texts from the middle and northern European immigration countries – is that in contrast to earlier schoolbooks, they contain a great number of instructions, tips and techniques for individual learning. These suggestions directly address the students and support them with the following questions:

- ▶ How do you solve learning problems when reading?
- ▶ How do you orient yourselves in reference works and on the internet?
- ▶ How do you recognize what is important in reading a text?
- ▶ How do you plan the structure of a text or a presentation?
- ▶ How do you provide good feedback in a conversation?
- ▶ How can you identify to which part of speech a word belongs?



Hints, techniques or strategies of this kind were hardly ever taught in previous textbooks. The focus then was the mediation of factual knowledge or general expertise – e.g. in grammar – the training of this technical expertise through reproductive exercises. In many countries and cultures, this is still more or less the case today. This is also reflected in the fact that in those countries and languages there are few, if any publications devoted to learning techniques and strategies, whereas those in the central and northern European countries fill entire bookshelves.

The reasons for these differences are the developments in and focal points on the new pedagogy, didactics and methodology in the immigration countries. These are described in detail in Part II of the handbook and workbook “Foundations and backgrounds” (see chapters 3–6). To mention just a few of the keywords, the higher emphasis on autonomous learning vs guided learning, the new understanding of the role of the instructor as learning coach, the orientation of classroom instruction not primarily on the substance of the program, but on the learners themselves and on developing and expanding their competences. Moreover, the recognition that factual knowledge becomes quickly obsolete in our fast-paced and highly mediatised world, whereby it becomes increasingly important to have acquired the techniques and strategies for information gathering and know-how to help oneself. (Example: those who only learned a bunch of facts in natural science or history are less competent than those who know how to acquire and process new information from the internet or from reference works, and to process and implement that information into a good presentation, for instance.)

As a consequence, the mediation of strategic knowledge (strategies for using information, learning and problem solving strategies) versus the mediation of pure factual knowledge occupies a significantly broader space in the more recent middle and northern European teaching traditions. This is reflected in classroom teaching and in the teaching materials, as well as in the fact that we are devoting an entire volume to the topic of learning strategies and techniques in the series “Materials for heritage language teaching”.

### 3. The role of HLT in mediating learning strategies

Students who attend HLT classes are primarily educationally socialized in the immigration country where they receive the major part of their education. However, in HLT they are also exposed to the pedagogical traditions of their country of origin. These two traditions differ more or less widely, depending on the age, the personality, the place of training and the origin of the instructor. This may become an issue for the students if they are used to expanded learning and teaching methods or forms of autonomous learning from their regular classroom education, whereas HLT classes are conducted with a more teacher-centered approach. It would undoubtedly be optimal in terms of efficient and sustained learning if there were as few rifts as possible between HLT and regular mainstream education. The aim of the series “Materials for heritage language teaching” is to bridge them and to promote precisely the kind of cross-linking described in the foreword above.

The mediation of training and learning strategies and techniques is an area in which HLT and regular classroom instruction can collaborate and complement each other in a fruitful and mutually beneficial manner. On the one hand, HLT students have acquired from regular classroom instruction already a series of techniques and strategies which naturally can be used and practised in HLT as well. On the other hand, HLT can introduce and test learning strategies which can also be useful to the students in their mainstream education classes. The reason for this particularly effective cooperation in the area of learning strategies is that they are largely language-independent or rather can work across languages: those who have mastered the technique of orienting themselves in Turkish dictionaries and encyclopedias can transfer this easily to the reference works in the language of the school; those who know how to organize their work in preparation for a test or a presentation, can use this competence for tests and presentations in all kinds of possible languages.

Another aspect of considerable importance for the role of HLT in mediating learning strategies, techniques and applying them remains to be mentioned: many “local” children and adolescents in the immigration countries (particularly those from educated families) have already acquired certain learning techniques and work strategies. This foundation is lacking for many children and youths whose parents and grandparents emigrated from countries with a different learning culture. Affected are primarily the students from educationally rather disadvantaged families who do not have a corresponding background. They are in particular need of support, and HLT can help them especially well in that it meets them in their primary language and in a less stressful area.

The ten-step training program for successful learning is designed to target these children and adolescents (see Part II, chapter 4).

This chapter concludes with two important aspects for specific implementation of the work: the coordination with mainstream education and four methodological-didactic key points.

### **Coordination with regular classroom instruction**

In consideration of the interlinking and sustainability aspects when introducing and working with learning strategies, the three following points are of particular importance:

- a) The closer the collaboration between the instructors of HLT and mainstream education teachers, the higher and more effective is student success. This is true in general, but also applies for the work with learning strategies and techniques. Optimally, there would be a direct exchange and coordinated planning whereby, for instance, the techniques of clusters and mind maps or the internet orientation would be tried out parallel in HLT as well as in regular classroom instruction. This could be connected with a common factual topic from geography or history (rivers; middle ages) or with similar assignments (collecting ideas for writing a fantasy text; compiling and preparing information for a presentation).
- b) Where a direct, intensive cooperation is not possible, HLT instructors should at the very least gain an insight into what kinds of learning strategies are mediated in the teaching materials of the regular mainstream education classes (particularly in the language texts) with which the students should be more or less acquainted.
- c) With each learning strategy and technique which the students acquire in HLT classes, there must be discussions as to where and when the respective technique can be applied, not just in HLT, but also in regular mainstream education classes (for which subjects, assignments, for training of which content, etc.). It is also important to clarify if the students have already had experiences with the respective technique (or similar ones) and how these experiences can be expanded and optimized.

### **Methodological-didactic key points**

The following points are important in order to permanently internalize and render the learning strategies applicable:

- d) Learning strategies and techniques should not just be introduced and explained one time. It is important to elucidate carefully when introducing them and to test and apply them repeatedly by way of concrete task assignments (the materials in Part I are, of course, very helpful for this purpose). The didactic recommendations for the materials in Part I offer many hands-on suggestions for this purpose.
- e) In order to truly adapt and internalize the individual techniques and strategies, their introduction and application must occur carefully (see above) and at intervals of a few weeks. If several learning techniques are introduced at once or within a very short time interval, the risk of confusion or forgetting is significant.
- f) It is imperative to discuss the students' experiences at the introduction of the new techniques as well as during and after their implementation: What has the new technique produced? Where did I have difficulties? How could I optimize my working with this technique? What kinds of tips for working with this strategy can I give to my classmates?
- g) Last, but not least, it is important to reiterate once more the above point c) i.e., the conversation about where the respective strategies or techniques could be used and applied in HLT or regular classroom education.

## 4. About the 10-step training program in Part II

In the foundations volume of this series (Handbook and workbook: Foundations and backgrounds) the following passage relates to the challenges and tasks of HLT instructors (chapter 2.3):

“Particularly important is the mediation and thematization of all the prevailing unwritten norms and expectations in the host country, which are often totally unknown, especially to emigrated parents from underprivileged educational backgrounds. This includes, for instance, unwritten rules that are taken for granted, concerning the “right” time when smaller and older children should go to bed, what they should eat for breakfast or eat in general, how to deal with homework and the learning environment at home, etc. To be informed about such issues and to be able to pass on the information is an important task for HLT instructors.”

The problem with all these unwritten rules and norms is the fact that for the “locals” (at least those from educated, successful families), these expectations are so clear and internalized that they are hardly ever communicated explicitly. When even HLT instructors require some time to grasp the most important rules and expectations, this is much more difficult for parents or children who are distanced from education or more disadvantaged. The innovative 10-step program in Part II of this volume intends to address this by providing help in very specific and practical ways. It introduces the readers to the fundamental prerequisites for working effectively and for success in school. This includes, for instance, setting up quiet a work place, regular study hours, working with a plan, etc. For every step there are explanations, tips, and concrete implementation exercises. Working through the entire program (in a manageable 10–14 days) promotes practicing and rehearsing of the most important unwritten “rules of the game”, which would otherwise be unknown to many children and adolescents of socially and educationally less privileged families.

**For using the 10-step training program, a number of different scenarios are possible:**

- The program is being discussed and worked through in its entirety by the whole class, e. g. as a common project “we optimize our learning”. For younger children, the steps 5–10 must be age-appropriately simplified and adjusted.
- The program is administered with a smaller group of motivated students who would, naturally, also communicate their experiences to the others.
- The program is being worked through in conjunction with individual students or a few students who are educationally weak and receive little parental support. The parents and, if possible, the classroom teachers, should absolutely be included. In this case, the program has the function of an emergency measure, as an effort to save the students’ jeopardized school career.

Working through this program without any parental support can be an overload for many students. It is therefore all the more important to inspire the parents’ support and enthusiasm for this project within the context of HLT, particularly since the instructor generally only sees the students once per week. What the HLT instructors can accomplish in terms of a successful project with the 10-step program can be summarized as follows:

1. Inform the parents about the project “Working through a training program for successful learning” and about the unwritten, but essential school-related rules and norms. This works best in conjunction with a parents’ event or a discussion with parents, supplemented with an information sheet (see below). In lieu of a meeting with a parent, at least the information sheet should be provided. Optimally, this program should be coordinated with the teachers of mainstream education classes. It is highly likely that they would be interested in the 10-step initiative.
2. In copying the program from Part II of this volume, collect and staple the pages together into a booklet and distribute them to the students.
3. In the two weeks where the students work through the program, discuss their experiences, problems and successes in class. Make time for discussions, suggestions and exchanging tips. Similarly, conclude with a follow-up discussion with the students after the end of the program.

## Sample of an information sheet for the parents (template intended for adaptation as needed)

Dear parents,

As part of the native language education program, we would like to assume a training program, designed to ensure acquiring the prerequisites for successful learning. These prerequisites are of vital importance for your child's success in school. As parents, you should endeavor to help your child fulfill these requirements, if at all possible. The program is comprised of ten steps. Your child will receive the program outline in form of a copied booklet. The steps outline, among other things, the importance of setting up a work space, the importance of maintaining fixed work hours and prior planning of one's work. There is a short exercise at the conclusion of each day. This program should be concluded in about 10-14 days of work. Your supporting your child and taking an interest in his/her work with this program will help a great deal to ensure his/her persevering and really working through the program. Your support does not demand much time. It simply consists of making sure every day during that 10-day period....

..... that your child continues to work through the program and has completed and understood the corresponding step and its related exercises.

.... following the conclusion of the work on a particular step, engage your child in a short conversation about the following points: How did it go? Is everything clear? Show me the completed exercise or the assignments related to this step! (Maybe your child may still need a little help from you in this regard).

It goes without saying that the program will also be discussed in our lessons, but this does in no way replace your vital support.

I thank you in advance for your interest and your help in carefully working through this program. I can assure you that your assistance will make a valuable contribution to your child's approach to learning and student success.

With kind regards,

---

## Bibliography

Endres, Wolfgang (2004): 111 starke Lerntipps.  
Sek 1. Weinheim/Basel: Beltz.

Endres, Wolfgang et al. (2008): So macht Lernen Spaß. Praktische Lerntipps für Schülerinnen und Schüler. Weinheim/Basel: Beltz.

Hinnen, Hanna (2007): Ich lerne lernen.  
Lernstrategien und Lerntechniken (3.-5. Klasse).  
Zürich: Lehrmittelverlag des Kantons Zürich.

Hinnen, Hanna (2009): Lernen kennen lernen.  
Lernstrategien und Lerntechniken (6.-9. Klasse).  
Zürich: Lehrmittelverlag des Kantons Zürich.

Keller, Gustav (2011): Lerntechniken von A-Z. Infos, Übungen, Tipps. Bern: Huber.

Kruse, Gerd; Maria Riss et al. (2010, 2012, 2013):  
Lesen – Das Training. Unter-, Mittel-, Oberstufe;  
je Teil 3: Lesestrategien. Bern: Schulverlag plus  
Mandl, Heinz; Helmut F. Friedrich (2006): Handbuch  
Lernstrategien. Göttingen: Hogrefe.

Schader, Basil (2013): Mein schlaues Lernheft.  
Zürich: Orell Füssli Verlag.

Steiner, Verena (2011): Lernpower. Effizienter,  
kompetenter und lustvoller lernen.  
München: Pendo.



**Part I:**  
**learning strategies and techniques**  
**for different sub-areas**

# 1

## Techniques and strategies for practicing in general (M1–4)

### Overview

*The materials M1-4 comprise general, comprehensive learning techniques and tips: **M1** offers eight short and simple tips for methods of working and memorization; **M2** shows how students can practice the comprehension and rendering of connections. **M3** and **M4** are somewhat more challenging. They show how to self-create efficient training aids (practice sheets with self-control, audio training, and flashcards).*

### Recommendations on implementing

All four sheets can easily be used for discussions of content relative to HLT. As always, the discussions with the HLT students should include references to typical applications in regular classroom instruction, as they should and must be able to apply these learning techniques there as well.

#### M1

It is useful to begin with the tips referenced in M1 (Practicing and training – reasons and a few hot tips). A good framework for this would be a class conversation about the topic of learning and learning tips. Following that, M1 will be distributed, read through and discussed. Who has already had experiences with which tip? The round ends with the question: Who tries out which tip for next week and reports about it in terms of which content? It would be good if for each of the seven tips one or several students would commit. The experiences of the “learning experts” will then be exchanged and discussed during the ensuing week. A second round can easily be implemented wherein all students try out another technique and report about it.

#### M2

M2 (Understanding content and rendering of content) is best introduced and implemented in terms of a specific HLT topic (e. g. a theme from the history of the country of origin, from grammar, or a literary or factual text which has to be rendered accurately). Here too, “test groups” are formed which report the following week about their experiences. This way, the students get to know as many learning techniques as possible. This sheet should repeatedly be the subject of class discussions.

#### M3 and M4

M3 and 4 show three somewhat more challenging, but highly efficient learning aids (self-made practice sheets, training with audio media, flashcards). It is certainly useful to carefully discuss the suggestions in terms of a classroom lesson topic and to illustrate it by creating a specific example together with the students.

## Why practicing at all?

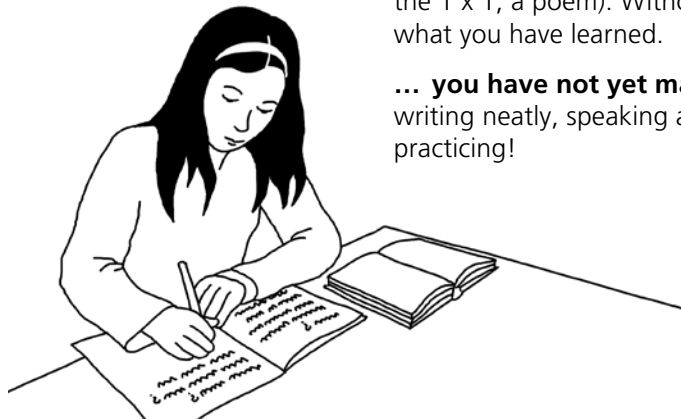

### Practicing is always important when ...

... **you must not forget something** (e. g. words from another language, the 1 x 1, a poem). Without practice, you would right away forget again what you have learned.

... **you have not yet managed to do something well** (riding a bicycle, writing neatly, speaking another language). It does not happen without practicing!

## Try out the following tips and techniques!

### 1.1

#### Divide your task into smaller steps or portions.

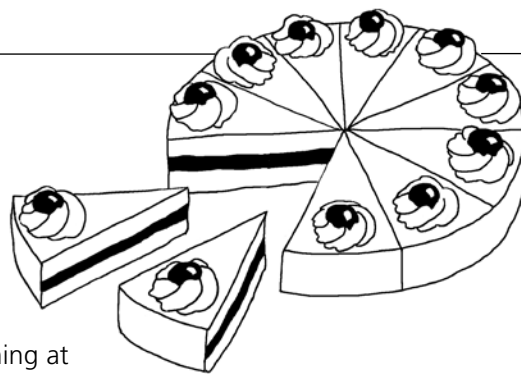

Don't practice everything at once; practice one part after another.

Example: if you have to learn 35 words (for correct spelling or for a foreign language): divide them in 5 portions (5 x 7 words). Practice one portion after the other.

### 1.2

#### Do not practice the same thing for too long; take a short break every 15 minutes!

Better than practicing at a stretch for an hour are three shorter practice sessions of 15–20 minutes.

### 1.3

#### Absolutely repeat what you have practiced various times during the day for various days!

Only this way does it remain permanently in your head.

### 1.4

#### If you need to learn something by heart, let someone question you.

If you need to memorize something (e. g. words, a poem, the 9 series, etc.), let a classmate, a sibling, or your parents question you. This is more fun than when you learn alone, and you know right away what you still have not yet mastered.



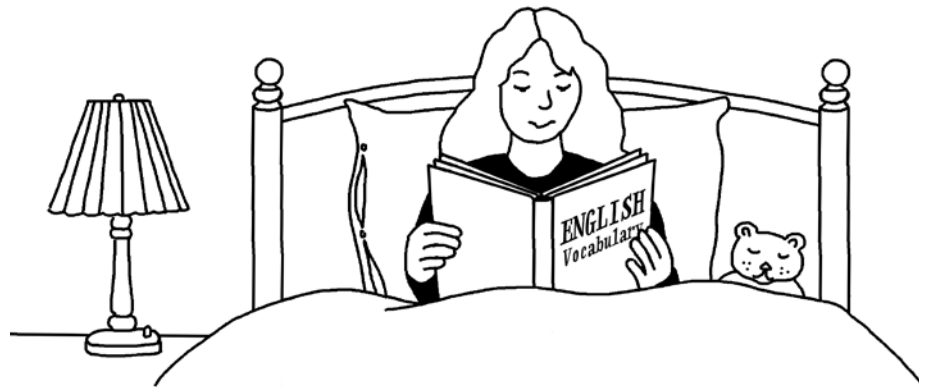

1.5

**What you practice before falling asleep, often remains firmly etched in your memory!**

Repeat the difficult English words, the poem that you have to know by tomorrow, the 12 series or whatever you have to learn directly before falling asleep. Then, turn off the light and amaze yourself in the morning by how well you suddenly know what you have practiced!

1.6

**What you can illustrate with a sketch, a drawing or a diagram, you can store better than what you just think through in your head.**

The sketch will help you to think through what you have learned. It is a good tool for supporting the memory.

1.7

**A tip for learning words in a foreign language:**

These words are often easier to learn if they are embedded in a short sentence. For instance, do not just learn an isolated word, such as "the night", but write a short sentence with it (e. g. "The night is dark.") and learn it in context.



Many things just have to be memorized (words, dates, etc.). The issue is often the need to completely understand something, however. (Example: if you have to prepare for a test or a presentation or summarize a story.) The following tips will help you..

## 2.1

### Make a reminder



What you just read is often quickly forgotten. You will learn much better if you summarize in your own words what you have read or learned. The following is an intensive method:

1. Read thoroughly what you have to prepare. Mark everything that is important in the text.
2. Write down the most important things that you have read and learned.
3. Check if you have not forgotten anything. Perhaps you must supplement something.
4. Re-read your paper thoroughly one more time. Now take a much smaller paper (1/4 sheet).
5. Write on the small paper concisely and in small script the most important aspects of your theme. Check with your template if you have forgotten anything.
6. Try to summarize in your head everything that is written on the little paper, then compare it with the template or the larger paper.

## 2.2

### Create a learning poster

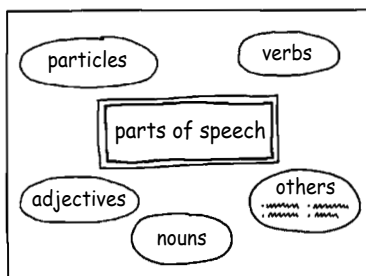

A learning poster is a large piece of paper (e. g. four A2 papers pasted together), on which you represent something that you have to memorize. (Example: parts of speech, difficult words, a graphic showing the structure of the earth, cities and rivers in your country.) Then hang the poster above your bed or somewhere else where you see it constantly.

#### Important:

- ▶ Write the topic of the poster as the title in large letters on the poster (above or in the center).
- ▶ Everything must be written in large letters and also be clearly visible from a distance.
- ▶ Use colors, sketches and drawings. You can also paste pictures on it.
- ▶ Hang the poster in a place where you can see it as often as possible.
- ▶ Look at the poster every time you pass by it.



## Telling the content to someone

When you need to comprehend, explain or summarize something: explain it to someone as accurately as possible!

It can be someone from your class or your family. If you don't find anyone; no problem. Simply place your teddy bear or a picture of your favorite star in front of you and explain to him/her what you have learned in a detailed and precise manner, so that s/he will certainly understand!

If you formulate what you have learned in your own words, you will know quickly if you have truly understood it.

### Tip:

Try to explain or to summarize what you have learned also in your mother-tongue! This is an excellent exercise and helps you expand your vocabulary.

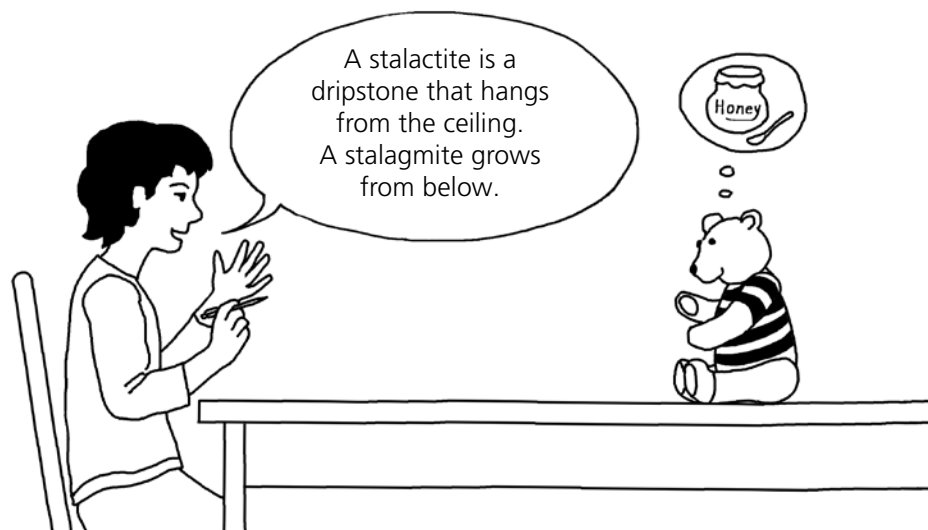

**I am going to try out this tip immediately:**

---



---



---



---



---

**In trying out the tips, I have experienced the following:**

---



---



---



---



---



---

## 3.1

### Write your own practice sheets – with built-in success control!

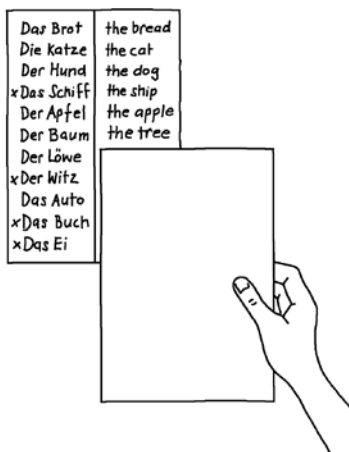

This approach is suitable for word training with a foreign language, multiplication tables, factual knowledge (year dates, places/countries, etc.) as well as for spelling training.

This is how it works:

Take a sheet of paper, draw a vertical line or fold it in the middle. Write the questions on the left side and the solutions in the right hand column (e. g. on the left side "der Apfel" and on the right side "the apple" or on the left "7 x 9" and on the right "63" or on the left "capital city Croatia" and on the right "Zagreb").

When finished, take a second sheet of paper and cover the right part of the test paper so that you only see the questions. Go through them one by one. Verify every time that you have given the correct answer. Mark with a cross those that you answered incorrectly, so that later on you will only have to practice those questions.

#### Tip:

If you can do this with a study partner (and each has a sheet), you will have twice as much practice material and more fun!

## 3.2

### Create your own training program with a sound recorder!

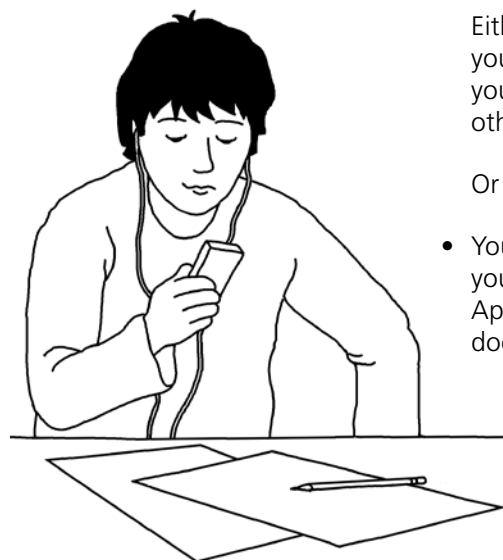

This is fun and ideal for preparing dictations, learning foreign words, but also for factual questions, such as dates, places, numbers or for practicing the multiplication tables. You can record sound with an MP3 player, cell phones and smart phones, with the computer or other recording devices.

This is how it works:

- Record the dictation text, the words or questions (speak clearly!). Make long pauses regularly. During these pauses you will later answer the questions orally or in writing. In the dictation text, make a pause after each word (or after every two to three words). With words from a foreign language, first pronounce the word in your language or in the language of the school, then leave a pause.
- There are two possibilities for solving the self-control issue:

Either you create a page with the solutions (in the correct order). When you listen to the recording and articulate the answers during the pauses, you can self-check your answers by uncovering one answer after the other on the solution page.

Or

- You create the recording as described above. However, after each pause, you also record the correct answer. Example for English words: "der Apfel" pause – "the apple". This variant is suitable for words, etc., but does not lend itself for the preparation of dictations.

## Flashcards: a useful aid for learning professionals

A learning box is a box with five compartments in which you can place cards or small papers with words (dates, formulas, etc.) that you need to practice. Practicing with flash cards really helps you retain the content of the cards in your memory.

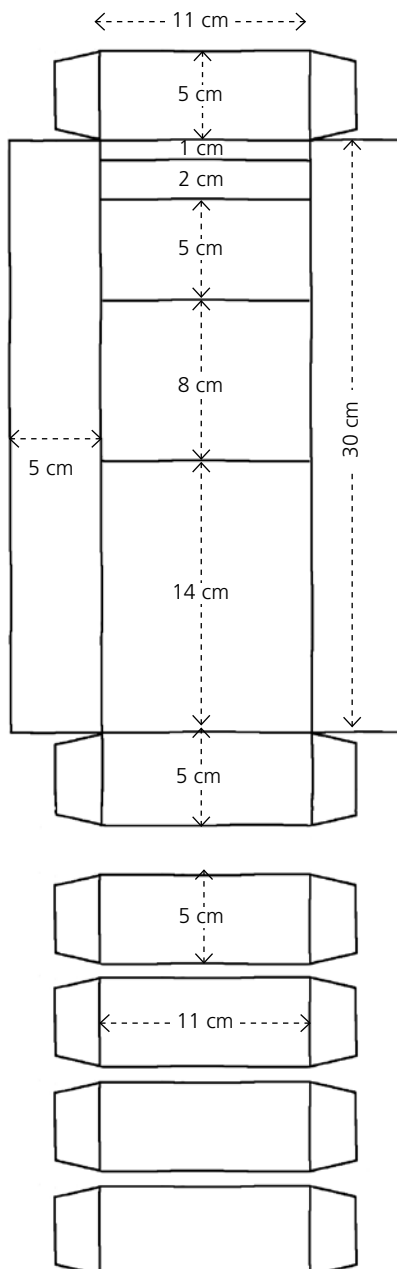
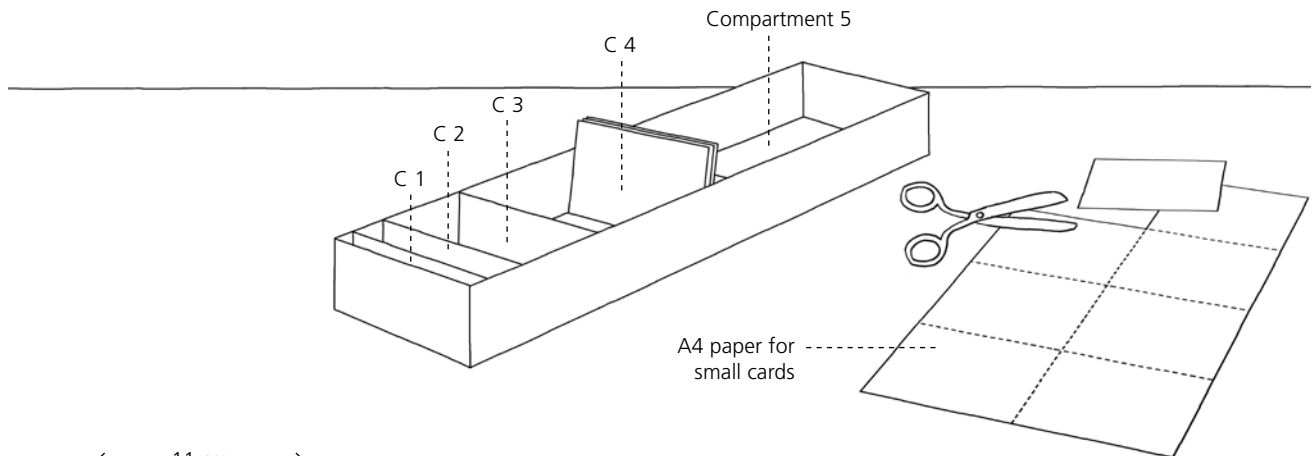

You can buy a learning box or create one yourself, as described. Also cut out 30–40 small cards (an A4-sheet yields 8 small cards).

### Tip

Don't just use the flashcards for words, but also for other school subjects (history, math, geography ...). Use different colors for each subject, as this helps you retain an overview.

### This is how you train with flash cards:

**Day 1:** Make your first 10–15 flash cards and place them into the first compartment (C1). Example for a word card in English: on the face of the card you write the word in English and on the back you write the meaning in your own language or in the school language. Practice with this card a few times until you know it. Place the ones that you know into compartment 2 (C2).

**Day 2:** First, work through the cards in C2. Place all those that you still remember into C3. Return the ones that you don't remember into C1 and practice with them a few times. Then create ten new cards, place them into C1 and do a few practice rounds with them. All of those that you have mastered are then placed into C2.

**Day 3:** First, work through the cards from C3. Place all those cards that you have mastered into C4 and return the others to C1 for further practice. Then go through the cards in C2. Those that you still remember are placed into C3, the others are returned to C1. Then, create ten new cards, work through them and place those that you have mastered into C2.

**Day 4:** (as well as in the following days): first review the cards in C4. Place all that you have mastered into C5 and return the rest to C1 for further practice. Then, review the cards from C3. Place those that you know into C4, the others into C1. Then review the cards in C2, place those you have mastered into C3, and return the others to C1. Then, make ten new cards, practice with them and place those that you know into C2.

Once a week (or every two weeks):

review every card in C5. Return those that you don't remember to C1 for further practice. Place those that you know into a special envelope and review them every two to three months!

# 2

## Techniques and strategies for using learning tools (dictionaries, encyclopedias, internet) (M5–7)

### Overview

*The materials M5-7 support the students in the competence to orient themselves with print and electronic media sources and to obtain information through them. These are considered key competencies and of central value in today's information society. HLT as well as regular mainstream education can and must support the students in developing this competence.*

### Recommendations for implementation

#### M5

M5 (Quickly locating something in a dictionary or an encyclopedia) begins with the mastery of the alphabet. This is an indispensable, elementary prerequisite in order to be able to use reference works and dictionaries. The various exercises should absolutely be gone through in class (and for further practice at home), until all students can easily orient themselves in the alphabet of their first language. This is level -appropriate from the 3rd grade on. At the same time, the differences between the letters and their sequential use in the first language and the language of the immigration country should be emphasized. In contrast to many other handouts, M5 requires a close monitoring by the instructor.

#### M6

M6 (Finding your way around books) supports the students in using books, particularly reference books and specialized nonfiction books. Students from educationally disadvantaged families in particular need help in this regard. This practice sheet is best introduced with specific hands-on examples. The instructor brings to class a few specialized texts about a current class topic (e. g. the history of Turkey) and reviews them according to the points raised in M6. The students are then asked to bring to the next lesson a specialized text (in the first or second language) and to introduce them to the class according to the criteria presented in M6.

#### M7

(To obtain information on the internet and elsewhere): the individual steps outlined on this sheet should first be discussed and practiced in class by way of a specific current topic (e. g. agriculture in Spain; the Roman epoch in the Balkans). In doing so, the use of information sources in the first language should be particularly emphasized and practiced. If possible, the instructor may also provide the class with a list of good internet links in the first language. As part of a later lesson, the students themselves should obtain information from the internet about a certain topic to share with the class. It must be ensured, of course, that all students have access to the internet, be it at home or through a classmate.

Other sources of information like libraries, conversations with experts, electronic consultation of experts, etc., should also be introduced and discussed with the students.

Many reference works are structured in alphabetical order: dictionaries for spelling, bilingual dictionaries, encyclopedias, phone books, directories, etc. These books are highly useful to us because they contain important information. We should definitely be able to use them. However, we can only do this if we have mastered the alphabet and know a few techniques.

**Caution:** the sequence of the letters in the alphabet is not the same in all languages, and many languages have special letters. Discuss this in class!

Here you will find the most important “game rules” and tips for using alphabetically ordered reference works. Practicing these with someone else is more fun!

## 5.1

### Memorize the ABC



Memorize the ABC until you can recite it by heart without problems.

Practice tips:

- Learn the letters in groups:

**ABCD**

**EFG**

**HIJK**

**LMNOP**

**QRST**

**UVW**

**XYZ**

- Sing a song with the ABC that you know, or make one up yourselves!
- Create a long strip of paper with the ABC on it. Cover a letter with your finger without looking. Which letter does it cover up?
- Write each letter on a small piece of paper. Mix up the small pieces of paper. Then draw two of them and decide quickly: which letter precedes the other in the ABC?
- Repeat the same with three pieces and arrange them in order of the ABC.
- Take the papers, draw a piece and decide quickly: where does this letter belong, in the beginning, the middle, or towards the end of the ABC?
- Draw a piece of paper with a letter. Then try to open the dictionary approximately where the words beginning with this letter are located (e. g. words with the letter B are near the beginning, those beginning with V are near the end of the alphabet).
- Make a list (e. g. animals or plants) and put them in alphabetical order.

## 5.2

### This is how dictionaries and encyclopedias are constructed:

All words are arranged in alphabetical order, based on their first letter (first come the A words, then the B words, etc.: ant – bear- chameleon...).

Within the rubric beginning with the first letter, the words are ordered according to the second letter (with A -words, first come those with aa, then those with ab, then ac, ad, etc.: aardvark – abate- academy – admiral).

Within the second letter, the words are ordered according to the third letter: abet – abhor – abide – abjure, etc.

Tips for practicing (this works better in pairs!):

- Make lists with names of animals or countries that begin with the same first letter (e.g. Italy, India, Iraq, Israel), then place them in alphabetical order according to the second letter!
- Take small pieces of paper and write words on them, taken from the dictionary that begin with the same first letter, Mix the papers and then order them according to the second and third letter.
- Take the dictionary, ask each other questions, such as: "What comes first: give or giggle?, dragon or dromedary?, forward or forget?"

## 5.3

### Use the headings!

Headings are the words which in most dictionaries are listed at the top of each page or double page. They tell you that on this (double) page, for instance, the words "island" to "isthmus" are listed. This way, you can quickly decide if the word you are looking for is referenced on this page.

Tips for practicing:

- Write down a few words, then look them up in the dictionary by concentrating specifically on the word headings.
- In pairs, ask each other questions, such as: "What are the headwords on the page where 'elephant' can be found?" – "Between which word headings can the word 'funny' be found?"

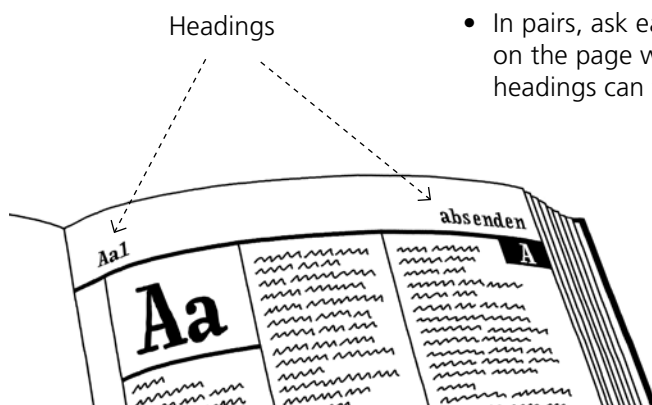

## 5.4

### You must know this as well when you look up things in the dictionary:

- If compound words cannot be located, you must look up the words individually. (Example: if you are unable to find the word "snowman", then look up "snow" and "man").
- Nouns are always listed in the singular form. Thus, if you are searching for the plural of a noun (e.g. "apples"), you must look for it under the singular form ("apple" where you will also encounter the plural "apples").
- Verbs are always listed in the infinitive (not conjugated). Hence, when you are looking for a verb in a certain form (e.g. "he sees"), you have to search for the verb in the infinitive or basic form ("he sees" can be found under "to see").



# M6

## Finding your way around books

---

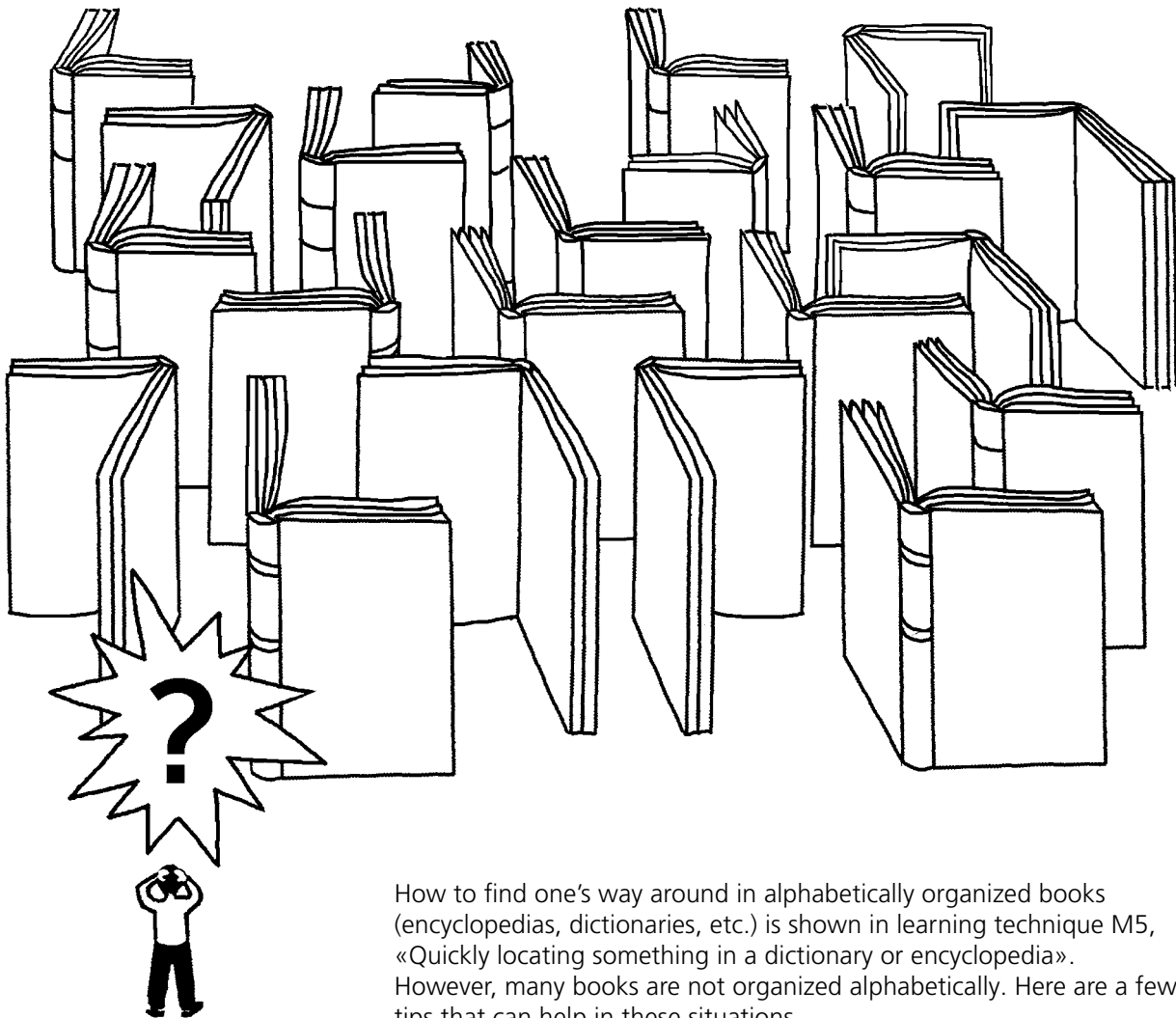

How to find one's way around in alphabetically organized books (encyclopedias, dictionaries, etc.) is shown in learning technique M5, «Quickly locating something in a dictionary or encyclopedia». However, many books are not organized alphabetically. Here are a few tips that can help in these situations.

---

### 6.1

#### **Look through the table of contents**

This applies most of all to non-fiction, factual texts. In the table of contents you can specifically search for something you want to know. Once it has been located, you only have to review the pertinent chapter and not the entire book!

---

### 6.2

#### **Check if there is an index at the end of the book.**

Many specialized books have an alphabetically organized index of keywords at the end of the text. That is where you can find without problems the passages and pages about a topic of interest. You must absolutely check if the book has such an index. This will save you a lot of time.

---

### 6.3

#### **Read the spine text**

Most books have a text on the back of the book with a short summary. This gives you a rough insight into what it is all about, without having to read the whole book. This is very practical.

## 6.4

### Read the jacket blurb or the short description on the first or second inside page.

Most books contain a short summary on the inside fold of the cover jacket or on the first or second inside page. They often contain information about the author as well.

It is very important that you read these texts. They provide you with very good insights without much effort.

---

## 6.5

### Read the introduction or the preface

Many books have a foreword or an introduction with a concise summary of what you can expect from this text. If a book has a preface or an introduction, it is worthwhile in any case to at least briefly skim through these pages. They provide you with good insights, so that you can make an informed decision about whether you really want to read this book.



### And another tip:

The more you work with books, the faster you capture their essence. Therefore, go to the library time and again and check out books for yourself!



The internet is an excellent source of information, particularly if you can use it in two languages. It is easiest if you proceed this way:



- Choose a good search engine, e. g. Google (enter [www.google.com](http://www.google.com) ).
- Enter a keyword as exactly as possible (better: two or several keywords) about your topic (e. g. «lion, fables», if you are looking for fables with lions, or Turkey, pictures of Istanbul» or «Portugal, agriculture»).
- Most of the time you will first receive a large selection of websites. First, look if wikipedia is among them. Wikipedia is a good language internet encyclopedia and is available in many languages. (You can also enter [www.wikipedia.org](http://www.wikipedia.org) and then type your keyword into the search field).
- It is important that you also search the websites in your native language or enter a search term in your language into the Google search engine. Caution: you must spell the search terms correctly. If you are not sure, maybe a machine translation can help, such as Google-translator (<https://translate.google.de/>) which is quite good.
- In many languages, there are special pages for children and adolescents, (for instance, in German [www.blinde-kuh.de](http://www.blinde-kuh.de)). Find out if something like it exists in your language as well.
- It is also easy to get lost in the wealth of information. Thus, think carefully which pages (texts, pictures, audio files) are really useful for your purposes, and only print out those.
- It is also important to be aware of the many misuses that occur on the internet. Always remember the following points: never give out your address or your e-mail. Never get involved in dates or meetings. Do not order anything without your parents' permission. Do not click on links that appear strange. If in doubt, consult with your parents or your teacher.

## Tip

Don't forget that there are many equally important sources of information besides the internet. These include most of all the following:

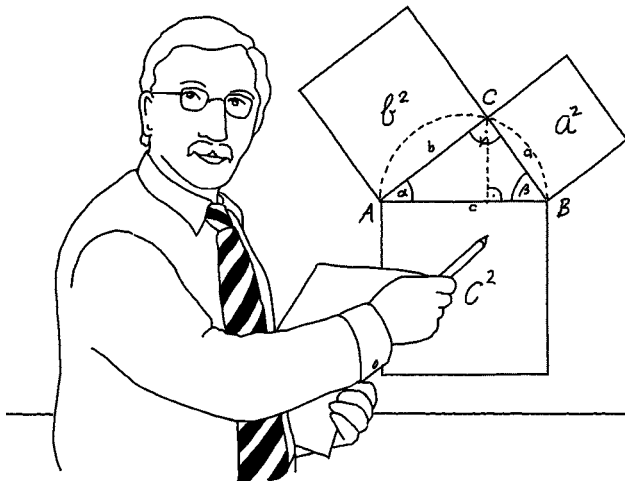

- ▶ Libraries (here you can find specialized books, encyclopedias, reference works, magazines, etc.).
- ▶ Conversations with experts in your environment (parents, acquaintances, specialists ...).
- ▶ «Electronic» interviews of experts (by way of e-mails, phone, skype, sms, etc....)

# 3

## Reading techniques and strategies (M8–10)

### Overview

*Reading competence is a key qualification of existential importance in today's information societies. This competence can and must, of course, be furthered in HLT as well, especially since the pertinent techniques are not tied to one particular language. A wealth of information can be found in volume 2 of the present series (Didactic suggestions for promoting reading in the first language). We are therefore limiting ourselves to three kinds of materials pertaining to the 5-step reading technique, i. e., notes, marginal notes and summaries. They support the students primarily in their independent work with more challenging texts (subject texts, literary texts), which must be understood, e. g., in preparation for a test or a presentation.*

### Recommendations for implementation

#### M8

M8 (Understanding the precise meaning of a text with the 5-step technique): it is useful to first discuss with the class the different ways of reading. (People read for entertainment, to obtain specific information, to get a rough overview of a topic, or to gain an exact understanding in order to be able to explain and reproduce it). The last point is important for texts and presentations, and the 5-step technique has proven highly successful in this regard. The five steps must be discussed and explained in class; most importantly, they must be (repeatedly) practiced and reviewed with the help of a specific text. This can be an HLT subject text, or individual texts which the students read in preparation for their presentations. The important thing is to discuss the experiences with the 5-step technique and to stress its value also for the mainstream education classes. Moreover, when discussing step 1, it should be related to M6 (finding your way around in books), and with step 4b, also reference M9 and M10 (notes, summaries). These three worksheets should have been addressed with the students previously or they should at least be implemented at this time.

#### M9 and M10

M9 (Highlighting essential information in texts; taking notes) and M10 (Creating good summaries) could either be introduced individually or they can be explained and implemented in conjunction with M8 (5-step technique). M9 explains the specifics of step 4b (Highlighting essential information, taking marginal notes), M10 (summaries) specifically deals with step 4c.

It is absolutely imperative that both worksheets be explained in HLT and that the training include practical applications with concrete assignment tasks. If the sheets are simply distributed, the risk of the students' not implementing and applying the described learning techniques is very high. For the techniques 9.1 and 9.2 (marking, marginal notes) the specifics of the technique are best elucidated with a factual text or a story. The same holds true for the three techniques described in M10, which are very useful in the preparation of presentations as well.

# M8

## Understanding the precise meaning of a text with the 5-step technique

You don't have to understand every text to the last detail. However, when you have to (or want to) thoroughly understand a text (e.g. for a test or a presentation), the 5-step reading technique will be an outstanding help. It functions as follows:

### Step 1

**Skim over the text to get an overview.**

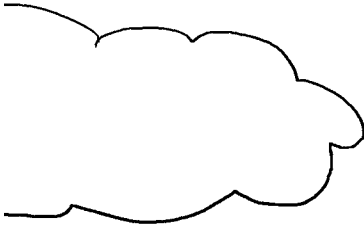
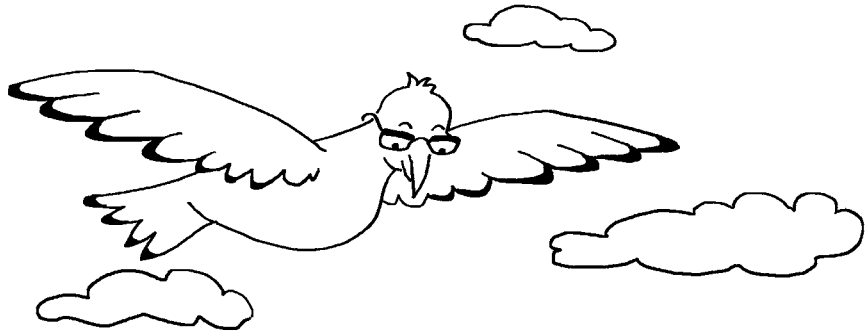

The goal is to obtain a rough overview of the text. For that, you must read all titles and all subtitles, look at the illustrations, and look into the individual sections. With books: read the summary on the back cover or on the first inside page, read the table of contents, look through the preface or the introduction.

### Step 2

**Ask questions of the text.**

What would you like to know about the topic of the text, what interests you? What do you know already? Write your questions on a sheet of paper and leave space for further questions.

### Step 3

**Now read the text thoroughly.**

Read the entire text in a concentrated manner. You can divide longer texts or books into shorter portions that you can manage (sections, pages, chapters). After each portion, refer to your questions from step 2, and think about what you can already answer by now. Perhaps you can add additional questions or mark an important passage already.



#### Step 4

**Mark anything important, answer the questions, summarize the text.**



- a) When you have read the text, review your questions from step 2 and 3 and answer them if possible.
- b) Mark anything of importance in the text (by underlining or highlighting; with a line or notes in the margin of the page). Use pencil, sticky notes or paper slips for books which you are not allowed to mark up.
- c) Create a summary of the text in your own words. It will help you to accurately think through the content of the text one more time.

#### Step 5

**Repeat the content.**

One or two days later: review the text with the markings from step 4b one more time. Try to summarize and represent the content in your head or on a piece of paper as completely as possible. Check and compare with the original to see if you have not omitted anything.

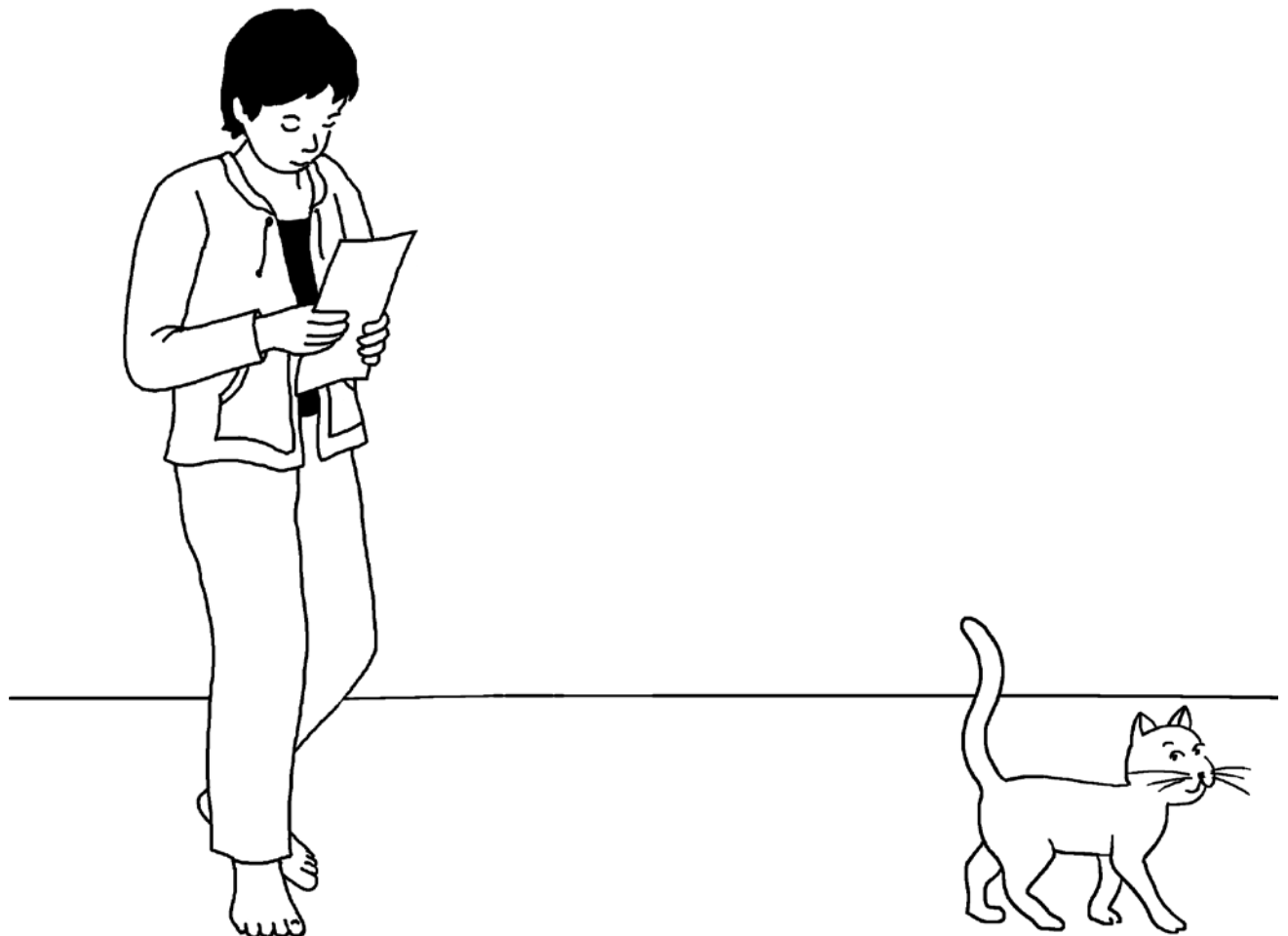

## 9.1

## Marking, highlighting, coloring



Important →

When you read the content of a text that you should remember (e.g. for a test or a presentation), it is best to mark the most important passages. This has great advantages: when you re-read the text, you don't have to focus on everything and can limit yourself to the marked up passages.

You can mark the text in various ways – try some of them!

- In books that must not be marked up (particularly borrowed books) it may be useful to lightly underline or draw a small line with a pencil in the margin. Other possibilities: insert bookmarkers to indicate an important passage or use post-it arrows or notes.
- Draw a short line or a cross in the margins: for very important passages draw a double line or an exclamation mark, or a question mark if things are unclear.
- Underline important words or passages, preferably with different colors.
- Highlight important words or passages with a marker. If you don't have a marker, make a circle with a colored pencil. Use various colors for this purpose as well.

## 9.2

## Marginal notes

It is also very useful to write notes in the margins.

- These can be keywords to a passage in the text (almost like subtitles; example: «rivers in Turkey», «racism today»), or
- remarks and questions about the content (example: «unclear», «great quote»).

With books that you cannot mark up, you can proceed as follows: insert book markers, post-it notes or arrows or other pieces of paper, referencing the passage with your commentary.

Clearly, taking notes is important for all sorts of possible reasons: to summarize something, to collect ideas, and to remember something.

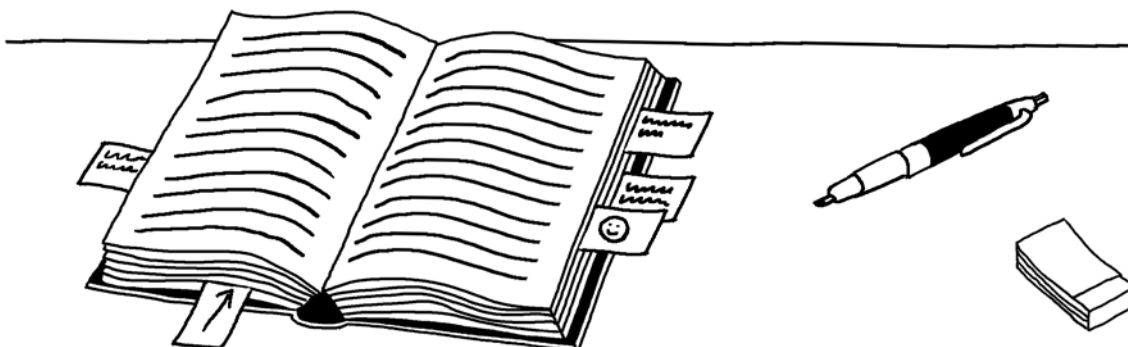

## 9.3

### To make your notes really helpful, you should consider a few tips:

- Write legibly, even when time is pressing. Illegible notes will not help you.
- Write a title on top of your page. Leave a margin of 4–5 cm on the right side for comments.
- Write in keywords; don't write complete sentences.
- Write down only really important details. For training purposes, try to summarize in 10–15 keywords a story or a newspaper article.

Example of a clearly arranged notepad:

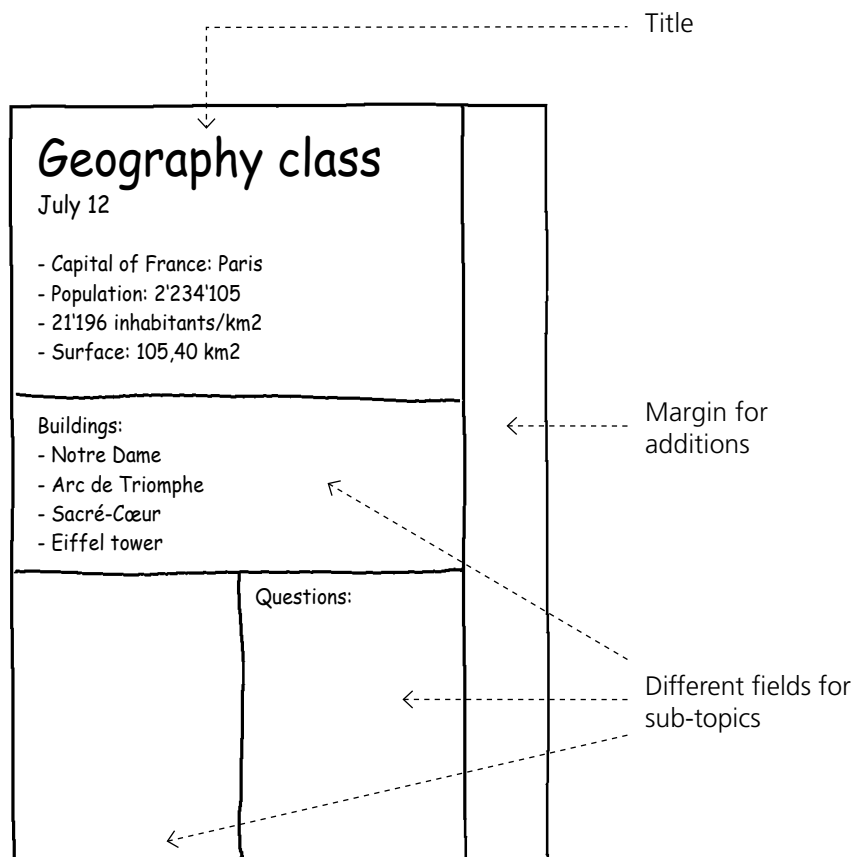

- Depending on the theme, it can also be useful if you sub-divide your notes according to different sub-topics. It is best if you divide your notepad into different fields and label them accordingly. Example: «most important contents», «also interesting», «questions», etc..
- Use abbreviations, arrows, symbols, sketches (e.g. "tel." for "telephone"; →; :-); ☺).



# M10 Creating good summaries

## 10.1

### The W-question tip

If you answer the **following questions** (with 2–3 sentences each), you get a **usable summary**:

- ▶ **Who** are the most important persons?
- ▶ **What** happened, what is the plot?
- ▶ **When** did the action occur?
- ▶ **Where** did the action take place?
- ▶ **Why** did it happen?
- ▶ **HoW** did it happen?

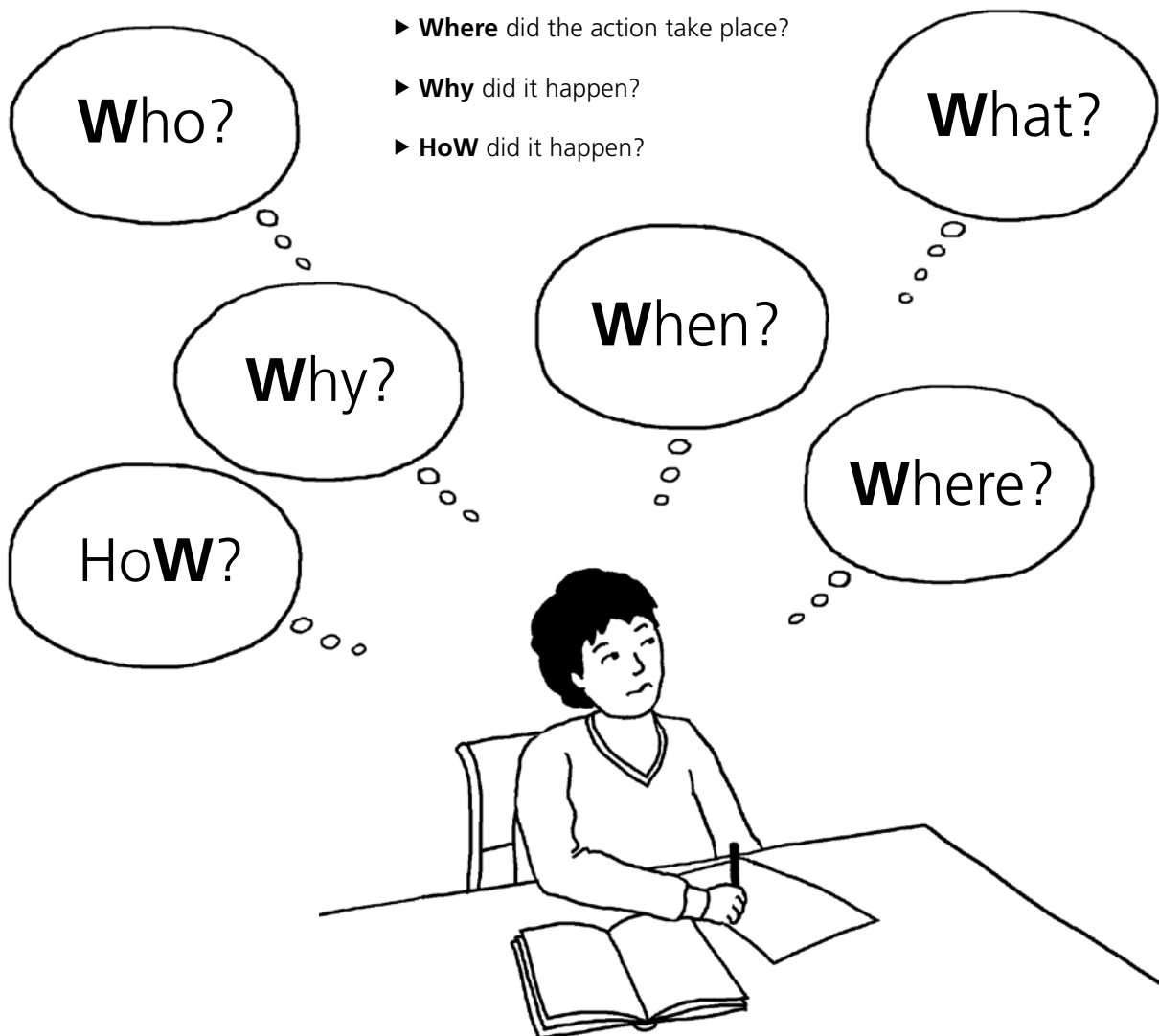

## 10.2

### Tips for summarizing books and stories:

- First, write down the following information: title of the text or story – author – publisher – number of pages – type of book (non-fiction, detective story, comic strip...).
- Write a very short summary (three to five lines).
- Briefly summarize the entire book or story, chapter by chapter (or part by part), limiting yourself to the most essential aspects.
- At the end, indicate why you liked the book or the story.

## A good scheme for summaries

- Take an A-4 paper and divide it with a ruler into approximate parts as below:
  - Leave a top margin of about 2 cm for the title.
  - In the right hand margin, leave a space of about 4 cm for later completion and expansion with keywords, etc.
  - At the bottom, leave a margin of 4 cm for personal remarks, questions, etc.
- In the title field, enter what you summarized. Example: "Presentation about the Roman period".

example of a well-structured summary:

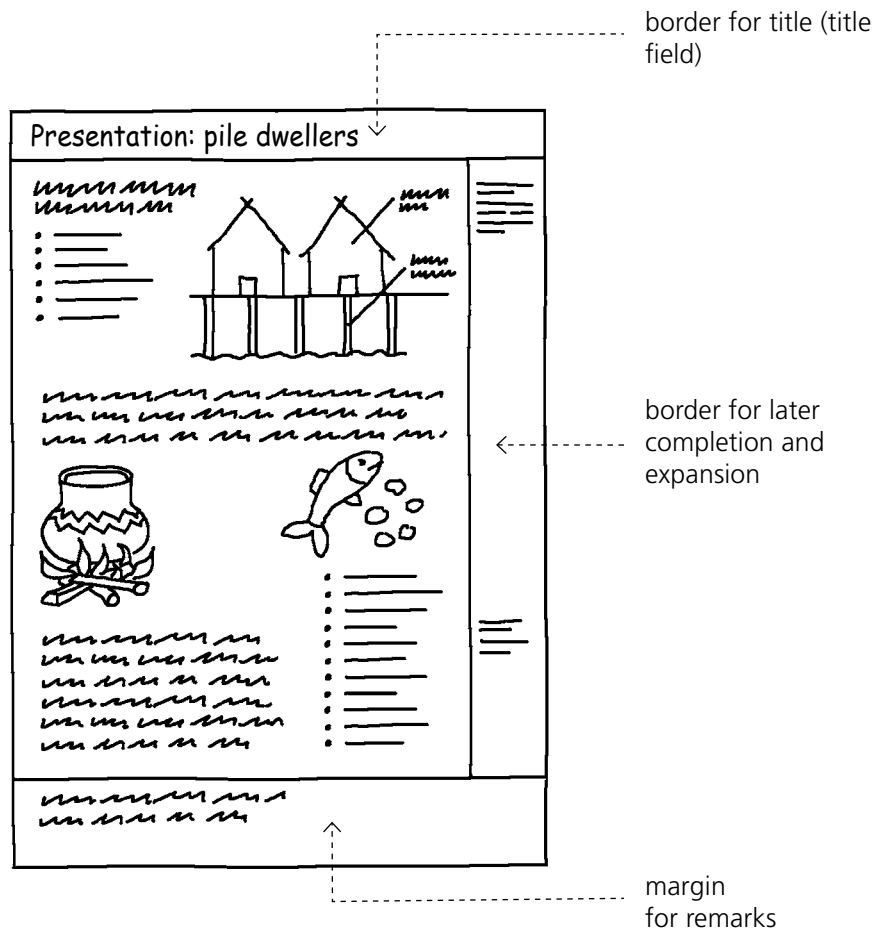

- In the large field, summarize the text (or the texts) you read about your topic. Only list the most important information. Write only keywords or short sentences. Use abbreviations. Subdivide your text into sections.
- Read and supplement your summary. In the right hand margin, write the most important keywords to each section of your text. At the bottom, write your personal observations and questions that you still need to clarify.

Re-read everything one more time in order to remember and memorize it well.

# 4

## Techniques and strategies for writing (M11–13)

### Overview

*There is no doubt whatsoever about the importance of literal competences – reading and writing. To have these competences at one's hands in the first language as well is an important prerequisite for a comprehensive bilingualism. Learning strategies and techniques are of significant importance as well for the promotion of reading and writing. Since they are largely language-independent and work across languages, respectively, the techniques that are introduced and practiced in HLT are also useful for regular classroom education – and vice versa. For a discussion of different aspects and ideas concerning the topic of writing, see volume 1 of this series (“Didactic suggestions for the promotion of writing in the first language”). In the following, we are thus limiting the scope to tips for finding and implementing ideas for writing with clusters, mind maps, and little papers, as well as two newly created worksheets from that volume which support the students in the conception of texts and in dealing with writing problems.*

### Recommendations for implementation

#### M11

M11 (finding ideas, planning texts with clusters, mind maps and small pieces of paper):

All three techniques, but most of all clusters and mind maps should be discussed and applied by way of various concrete examples. For the cluster method, imagination and association-related topics are most suitable. The mind map leads from the beginning to a higher degree of structure, which has proven useful with specialized topics or presentations. It is also possible to first create a cluster for a topic and to continue developing it further in form of a mind map.

For the first, teacher-guided attempts with both methods, the students could also work in teams of two (using A3 paper). As with all learning techniques, these should be the subject of discussion in class, as well, particularly the students' experiences with them, and the context in which the new techniques can be applied.

#### M12 and M13

M12 (Planning and revising a text – step by step) and M13 (dealing with writing problems) are newly-created versions of the worksheets 1 and 2 from the didactic volume 1 of the series «Materials for heritage language teaching» («Promoting writing in the first language»). First, M12 should be addressed, then M13. Before distributing them (or the larger originals from volume 1), it is useful to conduct a discussion about the steps of planning a text and about writing problems. A writing topic should be selected for specific implementation of M12, and the illustration of individual steps related to it. This should absolutely be repeated 2-3 times. M13 (dealing with writing problems) can be distributed and discussed during or after the first writing projects are handed in.

# M11 Finding ideas, text planning with clusters, mind maps and little notes

## 11.1

### The Cluster-Method

#### This is how you create a cluster:

Cluster signifies a group (of ideas). This technique gives free reign to your fantasy and your associations. It helps you collect ideas in a creative way and to determine a course of activity.

- Place a sheet of paper (A4 or larger, landscape format) in front of you. In the center write in large letters the appropriate theme or keyword (e.g. «homesickness», «discrimination», «dinosaur»). Circle these words.
- Now write around this word in keywords everything that comes to mind (all your associations, ideas, thoughts). Circle these words as well and connect them with the keyword in the center.
- You can write new words around each circled word and circle them as well. This way a whole network of ideas and associations emerges in the end.

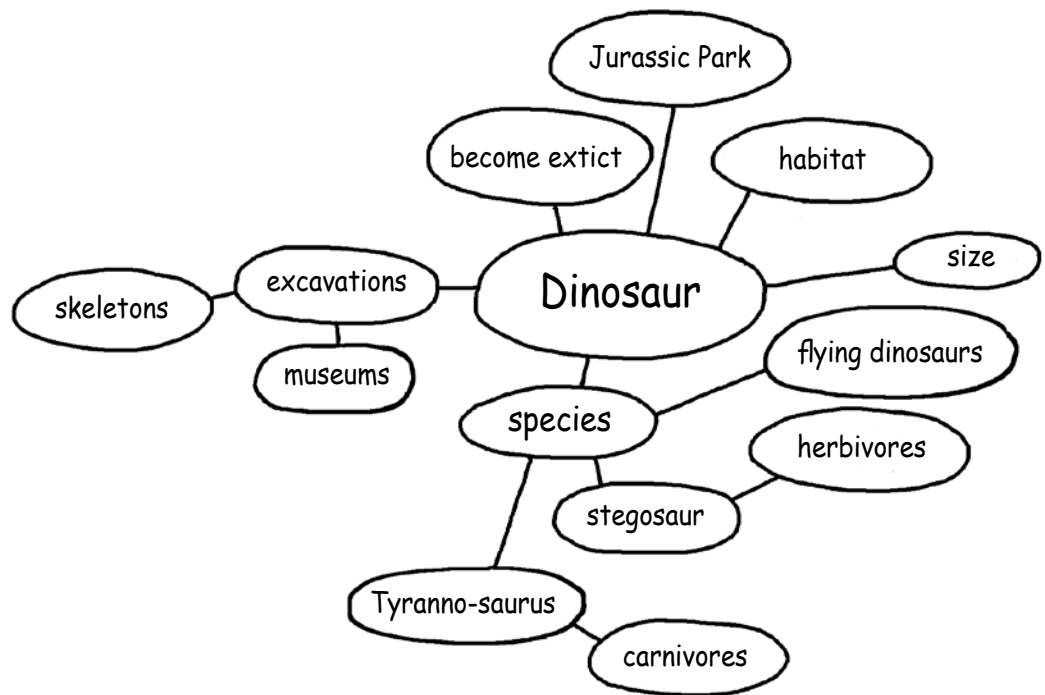

#### And so forth from the cluster to the text:

- Take time to consider your cluster.
- Then, think about which circled terms are connected in a way that would serve as the foundation of a text (essay, report, presentation). With another color, trace these connections or thought processes. Perhaps you will need several colors for different parts. Moreover, you may need to add different circles or connections for them.
- Continue working this way until you get a more or less clear idea how your text could be constructed. Use numbers to mark the sequence of thoughts, if this helps you.
- Now begin writing it down. Good luck!

## The mind map method

### This is how you create a mind map:

A mind map signifies a map of thoughts. This technique is particularly useful if you have to create a factual text or a presentation whereby the structure and the development is important from the very beginning.

- Place a sheet of paper (A4 or larger, landscape format) in front of you. Write in the center in large letters the appropriate theme or keyword (e. g. «nuclear energy, yes or no», «the history of Serbia»). Circle this word or these words.
- Draw a few main branches (thick lines) from this keyword for the most important partial areas or aspects of your theme. Label these main branches. (Example for nuclear energy: risks/usage/comparison with other sources of energy.)
- The main branches can branch into smaller, arterial branches.
- The arterial branches can also branch out further into even smaller branches.

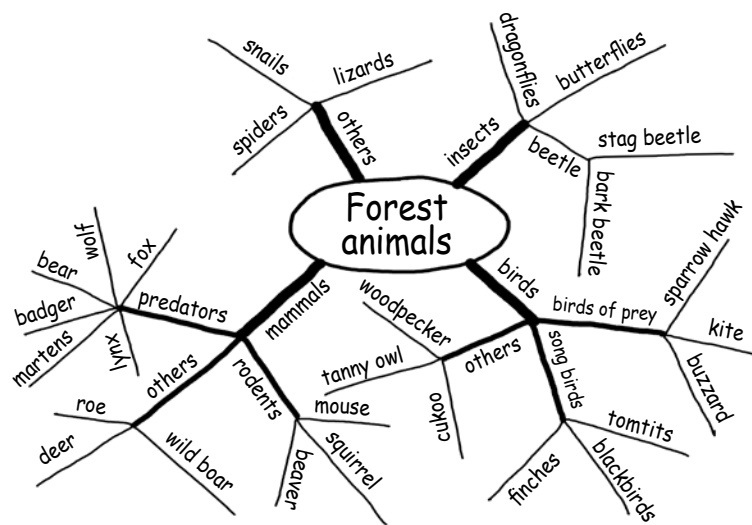

### And it continues like this:

- Take time to consider your mind map, and consider if anything important is missing. The mind map is finished (and a success) if it provides you with an overview of your topic, just like a map does.
- Depending on its intended use, it may be worthwhile to further elaborate the mind map (e. g. if you use it in preparation of a text or a presentation):
  - Use different colors and arrows to mark things that belong together.
  - Number the main and arterial branches according to how you are going to describe them later.
  - Perhaps use symbols; e.g. in order to mark things that you are going to illustrate with pictures in the presentation.
- Then continue with the next steps of your work.

## The little paper method

Cut out about 20 small paper strips and place them in front of you. Close your eyes until a thought about your topic occurs to you, then write it on the little paper. Each idea is written on a different paper. It may take a little while, or you may have to walk a few steps around the room until you have gathered a few thoughts about your topic. Once you have collected about 10–15 paper strips, put those together that fit and might be used for a text. Move the papers about and add different ones until you are more or less able to approximately imagine the text.

# M12 Planning, writing and revising a text, step by step

## Step 1

### Find good ideas for your topic!



#### Possibilities:

- Take a sheet of paper or different small pieces of paper and write on them everything that occurs to you about the topic. You may write the notes in the language of the school, if it is easier for you.
- If you have time, discuss the theme with different people. Write down their ideas.
- Create a mind map or a cluster if you already know these techniques.

## Step 2

### Arrange the ideas in order, plan the structure of your text

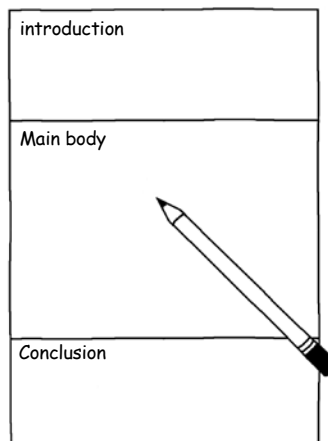

- Look through your notes or small papers. Strike through what you are not able to use.
- Take a sheet of paper and divide it into three parts as shown below:
  - introduction/overview
  - main body (large field!)
  - conclusion/summary
- write the ideas into the appropriate areas. Consider what is still missing and add it to the text.
- Continue working with this step until you can roughly imagine your text or your story.
- Consider also how you want to design your text (on a sheet of paper, by computer, with illustrations...).

## Step 3

### Write the first version of your text (draft)

- Write the text!
- Read through your draft, is the structure ok? Do you want to already improve certain words, forms or sentences at this time?

## Step 4

### Find an effective title and beginning

- Write a good title to catch the interest of the readers or listeners. For example, «Help, I am drowning!» sounds more exciting than «My vacation adventure».
- The same is true for the introductory sentence or paragraph of the text. Here, you can build interest and suspense. The important thing for a story is a surprising, exciting introduction, whereas clear information is required for a factual text.
- It is important to insert good and informative subtitles into longer texts and presentations. They help the readers get an overview.

---

## Step 5

### Revise the draft

- This works best with two or three classmates for mutual support and advice in form of a «writing conference». This allows you to help and consult with each other, but you can also revise your text by yourself. The following questions are useful for revising:
  - As a whole, is my text understandable and interesting? What do I need to formulate ideas more clearly? What is good, or not so good? Did I keep to the topic?
  - Does my text have a clear structure (introduction/overview, main body, conclusion/summary); is the sequence clear? Did I avoid straying from the theme?
  - Could I reword the title of my text to generate more interest and excitement, or that would provide clearer information relative to its content?
  - Does the text begin with an interesting or informative sentence that generates the desire to read on; how could I improve it?
  - Is every sentence understandable and correct in terms of forms and syntax? Mark uncertainties and clarify them with the instructor or someone else who is well versed in composition.
  - Did I choose clear and precise words; are there too many repetitions? Is the spelling correct (consult a dictionary!)?



---

## Step 6

### Create the final version of the text

- Make sure that your text is also appealing in terms of the presentation for the readers and exciting for the listeners!
- Also experiment with new forms (design with pictures or as a collage, with a computer, as audio text (audio file) etc.).

# M13 Addressing writing problems

**This page shows you how to solve a few frequent problems with writing.**

- ▶ When you have absolutely no idea about what you could write or when you have difficulties with building and structuring your text, then see page M12 «Planning, writing and revising a text»!

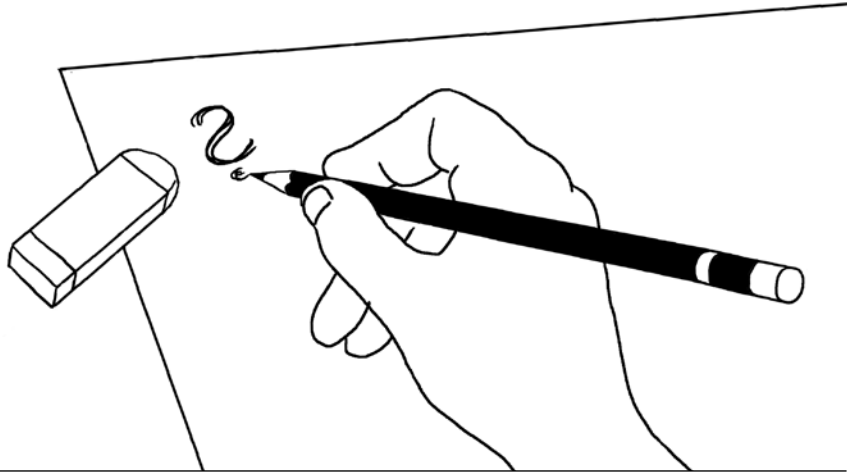

## Problem 1

**I have difficulties writing in my mother tongue.**

- ▶ When collecting ideas or writing a draft, you can also use words in the school language (e. g. German), if that is easier for you.
- ▶ If you have difficulties with dialect and the written version of your mother tongue or with correct forms, write the draft version in any way you can. Then discuss your draft with the instructor or with someone who has a good command of the written language. Have them explain to you what needs to be changed and why.
- ▶ Maybe the teacher will allow you to possibly write a shorter text, but as correctly as possible, or you may revise the first five sentences as correctly as possible.
- ▶ To ensure correct spelling, you should consult a dictionary in your language.

## Problem 2

**I cannot find an exciting beginning or an attractive introduction.**

- ▶ It is important that your text have an interesting title, even before you write the first sentence! You should also structure presentations and longer texts with subtitles.
- ▶ In a factual text or a presentation, a short overview of the content is usually provided. This helps the readers or listeners to better orient themselves.
- ▶ Even a story or an experience can begin with an overview: «I want to tell you how once I ...», «My story deals with ...».
- ▶ However, a story can also begin «in the middle», which sometimes can have an exciting effect: «I was lying on the floor as if I were dead. What could have happened? Slowly I began to remember...».
- ▶ A question to the readers or the audience can sometimes also be an effective beginning: «Would you like to know what I experienced last summer? Listen to this! It was on a ...».



### Problem 3

#### I don't know how and what I should continue to write.

- ▶ Read to someone or tell someone what you have written up to now, then discuss with this person how your text could continue.
- ▶ With a factual text or a presentation: consider a new aspect of your theme or a new sub-topic which you have not yet addressed.
- ▶ With a story: consider what the readers might want to know in greater detail. Write something about it. («Tom lay down on his bed and fell asleep.» → «You probably would like to know what Tom's bed and room looked like? I am glad to tell you: ...».)
- ▶ Read the last sentence of your text. Write another sentence where you refer to a word from this last sentence («Tom lay down on his bed and fell asleep.» → «He was sleeping soundly, until he suddenly startled, because he remembered that.... ».)

### Problem 4

#### I cannot find a good ending for my text.



- ▶ In a factual text, it is often good to write a short summary at the end («The most important points of my topic are ...».)
- ▶ It is also good to offer a personal opinion at the conclusion of the text: «What I particularly like in terms of this topic, ...», «In my opinion ...».
- ▶ It is also possible to directly address the readers at the end: «I hope that it became clear what I wanted to say», «How would you have reacted in this situation?».

### Problem 5

#### Help, my text is too short!

(See also problem 3 above!)

- ▶ With stories: invent a minor character (e.g. a cheeky mouse), that reappears again and again.
- ▶ Add an extra sentence or an extension to some of the sentences in your text (Example: «I was still very little at the time.» → «At the time, almost five years ago, I was still very little. I was at most six years old and had just started kindergarten.»)
- ▶ Extend the conclusion of the story. In a factual text, write a good summary, with a story, conclude with a personal opinion.

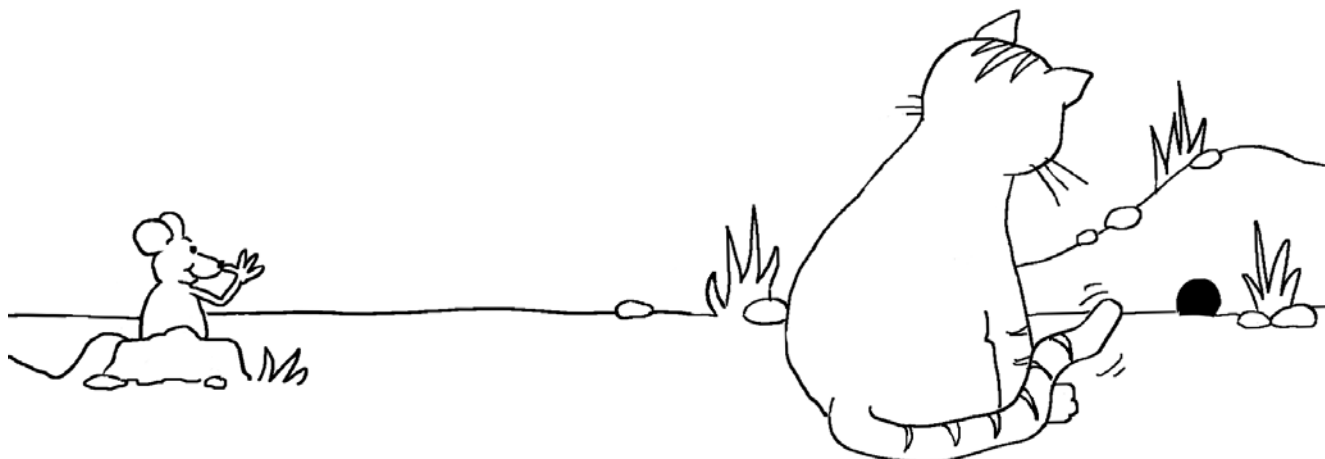

# 5

## Techniques and strategies for the preparation of presentations and tests (M14–15)

### Overview

*Giving presentations and preparing oneself for more extensive tests is part of the usual requirements, beginning with the fourth or fifth grade of primary school. Both of these requirements can mean a great deal of stress for many students, unless they are carefully guided in how to go about it. This can be a double blow for students who still have gaps in the mastery of the school language of their host country. The materials comprised in M14 and M15 offer concrete and detailed tips for both situations «preparing a presentation» and «preparing a test». Both suggestions can easily be adapted and applied in HLT. Here too, it is part of the standard curriculum that the older students give presentations and that, maybe at the conclusion of a larger theme or project, there may be tests or examinations for which the students have to prepare themselves carefully.*

### Recommendations for implementation

#### M14

M 14 (Preparing and delivering a presentation) is logically distributed and discussed in class at a time when the HLT students are preparing themselves to give presentations (be they about a topic in connection to the country of origin or about an aspect of growing up in the new homeland). The individual points raised in M14 should be explained and discussed with the students over a period of two to four weeks, in parallel to their preparing for the presentation. The objective must absolutely be that the students acquire the techniques and know-how that will serve them also for other presentations in HLT as well as in the regular mainstream education classes. In this sense, the detailed “methodical” discussions before, during and after the presentations are necessarily meaningful. Naturally, these discussions should also include experiences and strategies which students may have already acquired in regular classroom education.

#### M15

M15 (Preparing yourself for a test: tips and techniques) is best introduced and explained with examples in the context of a bigger examination. This could be a test about previously covered factual materials (e. g. from the history of the country of origin; a comparison of family structures or the politics in the country of origin and in the immigration country, etc.). It must be made clear to the students that this is not a matter of stress and the pressure of getting good grades, but that they should learn in HLT how to prepare themselves for more important examinations – something that will serve them as well in the mainstream education classes. It is imperative that the discussions also reference other pertinent materials in this booklet, such as the important learning techniques described in M1–4

# M14 Preparing and delivering a presentation

## 14.1

### Choice of topic

- If you may select the topic yourself, then consider carefully ...
- ... which theme, point of view or aspect interests you?
- ... if you already have previous knowledge upon which you can build?
- ... if you know people, books or other sources of information that could help you with your topic?

Think about all these points and take notes. Only decide on a topic when you are absolutely certain!

## 14.2

### Planning the work: creating an action plan

A big task must be well planned and divided into partial steps. The important thing is to begin early and to allow yourself sufficient time.

a) determine the concept and sub-topics	1
	2
b) Search for information	1
	2
	3
	4
	5
c) Writing a first draft	1
	2
	3
	4
d) Revising the presentation	1
	2
	3
e) Practicing the oral presentation	1
	2

Make an action plan for two to three weeks with the following work steps:

- a) Concept; determine the subthemes (1–2 days)
- b) Search for information (3–5 days)
- c) Writing a first draft (2–4 days)
- d) Revising the draft (2–3 days)
- e) Practicing the oral presentation (2 days)

Write the outline of this action plan on a large sheet of paper.

Record in this field every day exactly what you have done.

## 14.3

### Concept: determining partial themes/sub-topics and structural development

Consider and write down which partial themes you want to discuss and how you want to structure your presentation. Here are a few hints concerning the structure:

- In the beginning of the presentation you should give an overview and a short introduction to your topic.
- In the main part or middle section of your presentation you should address various parts or sub-topics. Consider carefully which sub-themes you choose and in which sequence you address them.
- In concluding, give a short summary or express a few personal thoughts and considerations about the topic.

Write the concept on a large sheet of paper. Study the individual parts and make notes about them.

## 14.4

### Seeking information: compiling everything worth knowing about the topic

Take a few days to compile all information about your theme and the various sub-themes. Include pictures, excerpts from an interview or things that you can show as interesting elements of your presentation.

Make notes about your information, using various colors.

## 14.5

### Writing a draft

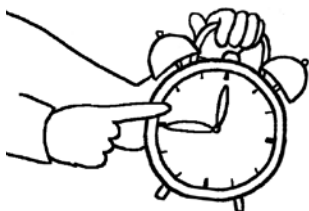

Write a first version of your presentation. Think about the time you have available! Note also when you want to show something (pictures, objects, something on the computer) and where you may want to involve the audience.

At the end, read your text aloud and time yourself. Are you more or less within the time frame that you have available?

## 14.6

### Revising the draft

Read your presentation to someone. *S/he* should tell you what was good, what was unintelligible and what was somewhat boring.

Go through your presentation section by section. Write a good, readable final version.

#### Pay particular attention to the following points:

- Make sure that you have an exciting introduction/beginning! Example: an interesting question, a personal anecdote, a surprising picture.
- Pay attention to a clear structure. Inform the audience about the structure of your presentation. Announce the beginning of a new chapter or partial theme.
- Strive for a simple, clear language. If there are technical terms in your presentation or difficult terms, explain them briefly!
- Include pictures, transparencies, the computer, audio documents, use YouTube videos or other media in order to render your presentation more lively and graphically.
- Make sure that the conclusion of the presentation is exciting as well.
- Example: you end your presentation with a question addressed to the audience or you summarize the most important aspects.
- Depending on the topic, you must also reference the sources of your information.

#### Consider also...

... if you want to prepare a few questions for a final discussion,

... if you want to prepare a worksheet or quiz with questions about the presentation,

... if you want to write a summary with the most important information for the benefit of your classmates.

## Practicing the oral presentation

Now give your speech a few times, just as you would do in class (including all pictures, media, etc.). The more freely you speak, the better.

It is particularly useful if someone is listening to your practicing of the speech. S/he can tell you, for instance, when you speak too fast or too quietly or whatever else is distracting.

### Proceed as follows when practicing:

1. In the beginning read the text off the page, but try already to sometimes lift your eyes from the page and make eye contact with the audience.
2. Mark the particularly important passages in the text and try to look only sometimes at the page. Otherwise, look at the audience and try to calmly move a little.
3. Now try to give the entire presentation freely without the text. To avoid forgetting something, you may create small cards or pieces of paper with keywords for every sub-topic.

### What should not happen:

- Speaking too quietly or too fast.
- Speaking in a monotonous voice, i.e., without changing the volume or the pitch.
- Rushing through the text, without ever making a pause.
- Standing stiff and cramped in front of the class without moving.
- Remaining glued to the pages, without ever looking at the audience.

It is best if you ask someone to observe you and to tell you what was good and what was not yet so good.

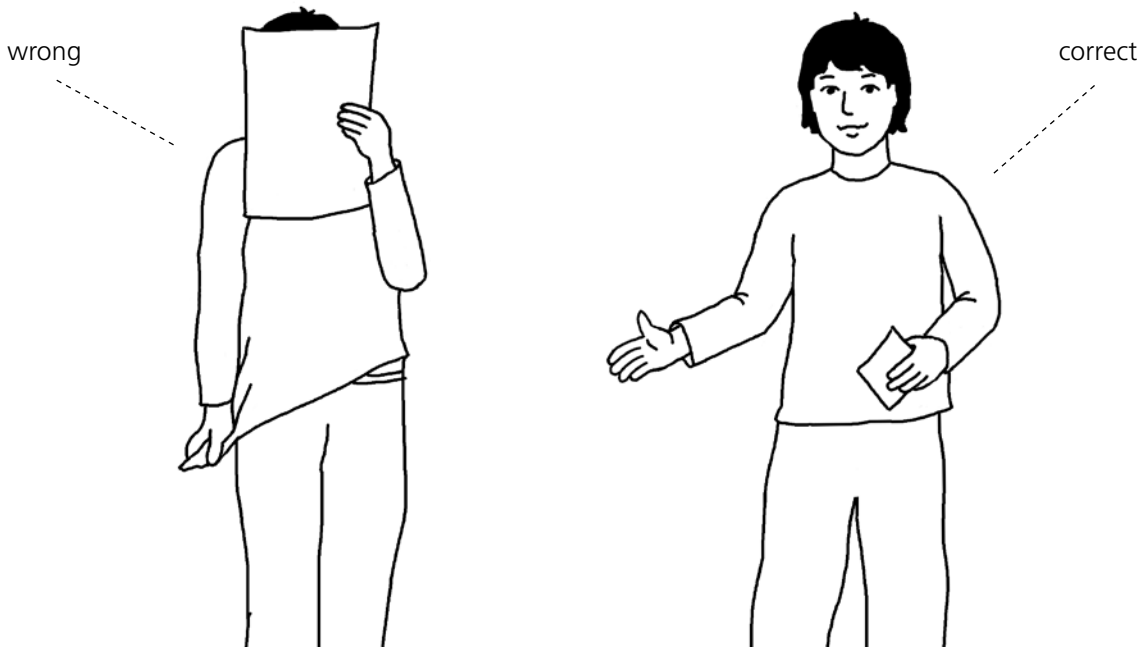

### And here is a last tip:

Before you give the presentation in class: check,

... if you have everything you need,

... if the technology functions (in case you make use of the computer and a projector).

# M15 Preparing yourself for a test: tips and techniques

## 15.1

### Before the test

To prepare for an examination or a test is not so difficult if one knows how. You have already learned many tips and techniques. In the following, we summarize the most important points and provide you with additional hints.

Structure your work carefully. Do not just begin with the preparations the night before the test under any circumstances! For more extensive examinations, create a program (an action plan) for your work over the next four or five days. Here, you see what this might look like:

#### Day 1:

Get a detailed overview of what you have to learn. Review everything, consider how to divide the material into three portions. Clarify in school anything that may not be clear.

#### Days 2, 3, 4:

Every day, thoroughly learn one of the portions. Briefly review the other two portions. See below how to study rigorously.

#### Day 5:

Repeat everything thoroughly one more time. Go to bed early so that you are well rested on the day of the test.

Your instructor can give you the following useful pages (if you don't have them already): «practicing and training – reasons and a few hot tips», «understanding contents and the ability to reproduce them» and «creating training aids yourselves». Review them and choose the techniques that match the subject of your topic!



Working in pairs is often a great help. This way you can quiz and support each other. Try to explain the material to someone else. Thus, you will find out quickly if something is not quite clear to you and what you still need to learn in depth.

When learning at home, and even during a test, a short relaxation moment can be useful. This applies particularly when you are stressed. Here are a few pertinent exercises:



- Close your eyes for a minute and only concentrate on your breathing.
- Take a DEEP breath and exhale FORCEFULLY five times!
- Extend and stretch.
- With your fingertips massage your head (forehead, temples, hairline).
- Try to fully concentrate for an entire minute on the second hand of your watch. Immediately wipe away any other thought.
- Close your eyes and imagine something beautiful, like a landscape from your vacation trips.
- Drink a sip.

## 15.2

### Before and during the test

Avoid any negative thoughts («I know nothing», «This is too difficult for me» usw.). Such thoughts only stress and weaken you; they are definitely not useful. Instead, remember positive thoughts, like:

«I have prepared myself well, and I am going to pass this test!»

«If others can do this, so can I!»

«Today is a good day, and I am going to pass this test as well!»

«I know so many learning techniques and tips that nothing can go wrong!»

### During the test, observe the following points:

- Get an overview before you start working:
  - What is the question exactly?
  - How many questions do I have to answer?
  - How much time do I approximately have for each question?
- Begin with an easy answer. This gives you a sense of achievement.
- Leave aside or skip difficult tasks for the time being. Otherwise, you might waste too much time with them.
- Carefully read through every question first. Begin solving the task only when you have understood it completely.

**Part II:  
the 10-step training program  
for successful learning**



## Step 1: adequate sleep and exercise



On the following pages, you will learn a lot about how you can learn and work better. However, all the tips and tricks will help you little, if you are constantly fatigued or run-down. The four recipes on this and the next page will show you aspects that are critically important and an indispensable prerequisite for success in school.

### Adequate sleep

#### TIP

Go to bed early every evening and turn off the light at the same time (10PM at the latest). Sleep at least 8 hours.

You will only be able to really concentrate in school and in performing your assignments if you are well rested. If you feel tired and run-down, you learn and work poorly or not at all. Therefore, please make sure that you go to bed at the same time every evening and that you get at least eight (8–10) hours of sleep. Turn off the light at 10PM at the very latest!

### Exercise

#### TIP

Actively exercise as much as possible every day. Before you go to sleep, think about what you have done for your body that day, and what you will do tomorrow.

People today sit far too much (in school, in front of the tv ...) and exercise too little. Small wonder that there are so many overweight people! The lack of exercise makes us sleepy and is harmful for our bodies and our brains. Make sure that you engage in sports and otherwise get as much exercise as possible: playing outdoors, walking, physical exercises at home.



### Exercise 1

Take a sheet of paper and write the title: «Sleep and physical exercise». On the next line, write today's date. On the line below enter: «Physical exercise today:... » (and indicate what exercises you engaged in and for how long). On the next line, record: «lights out at.....PM». Fill out the page in the evening today and for the next 10–14 days. Make sure that you always turn the lights out at the same time!

## Step 2: healthy eating, wholesome breakfast

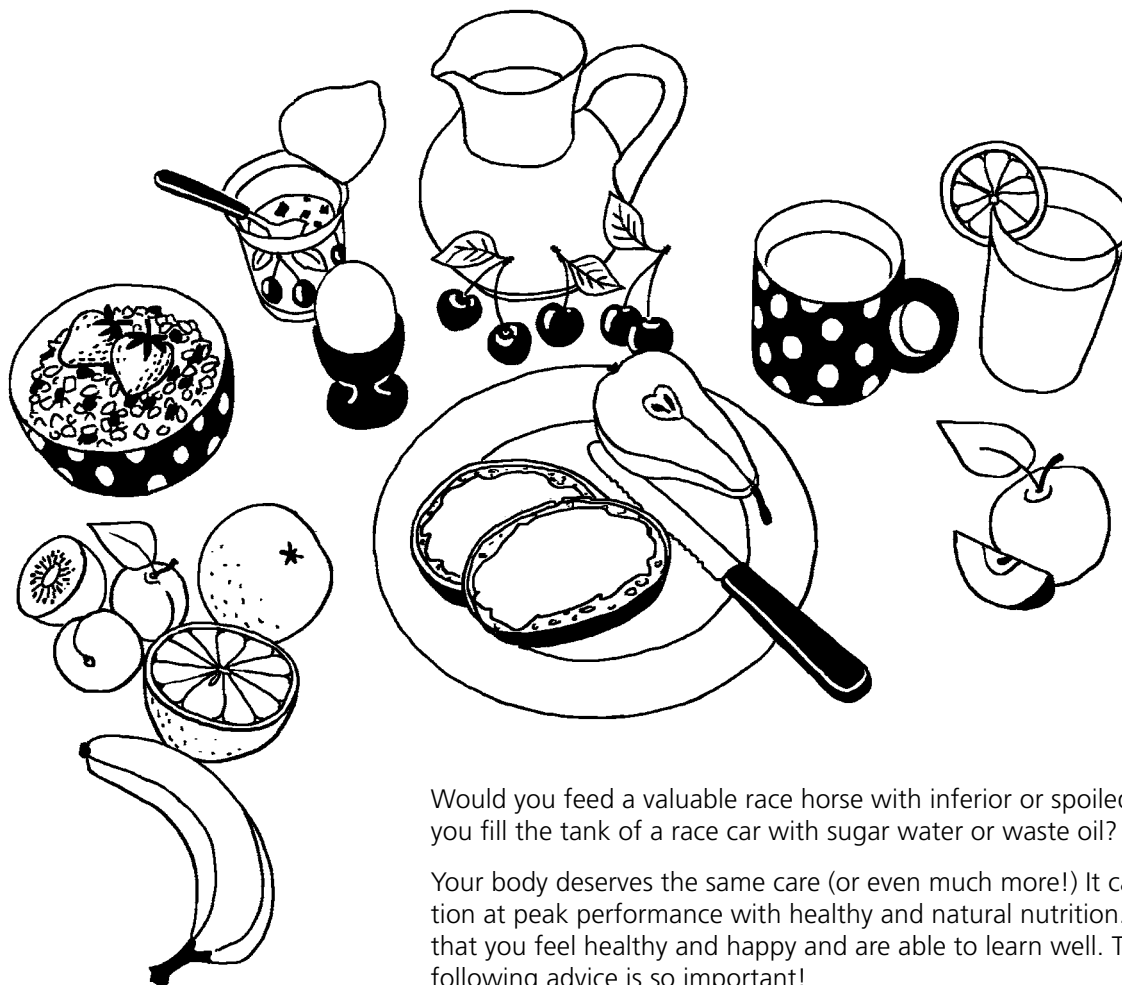

Would you feed a valuable race horse with inferior or spoiled food? Would you fill the tank of a race car with sugar water or waste oil? Of course not!

Your body deserves the same care (or even much more!) It can only function at peak performance with healthy and natural nutrition. This ensures that you feel healthy and happy and are able to learn well. That is why the following advice is so important!

### Wholesome food

#### TIP

Eat at least 2-3 pieces of fruit per day. Replace sweet ready-to-serve drinks with low-calorie beverages or a glass of milk. Only eat a small portion of fatty foods..

Your brain is like the motor of a luxury car. It only runs at peak performance with the best fuel. Fatty or overly sweet foods and beverages only make you listless and sleepy. The same happens when you eat too much. Avoid fast foods, fatty foods and sugary drinks like sweetened ice tea or sodas. Follow a natural diet with fruit, vegetables and milk!

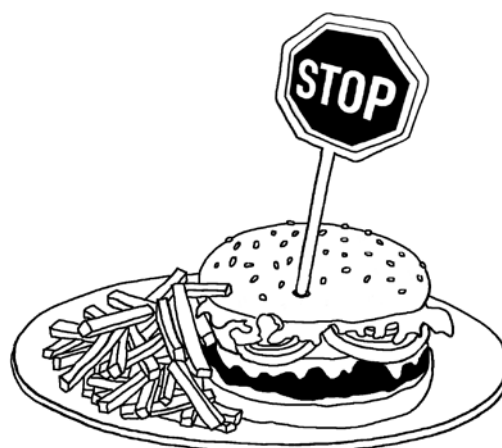

## Never go to school without breakfast

### TIP

For a week, deliberately pay close attention to eating a good breakfast and that you only consume healthful, wholesome and vitamin-rich food and drink for breakfast. Afterward continue doing this as a habit.

You must deliver the greatest output in the morning in school. For this to happen, your body and brain must be fortified with a good breakfast! Take time for breakfast and only eat and drink healthful and wholesome foods (whole wheat bread, cheese, milk, a piece of fruit). Take a sandwich or a piece of fruit along as a snack for recess.

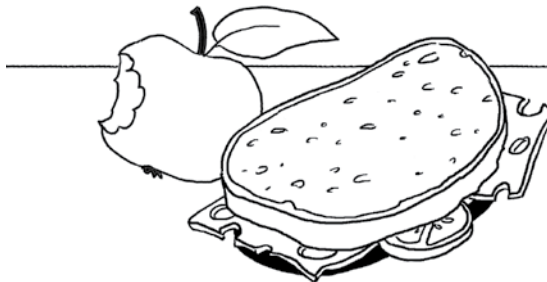

## Exercise 2

Take a piece of paper and write a title: «Wholesome food, a good breakfast». On the following line, state the date. On the next line, write «my breakfast today:...» (indicate what you had for breakfast). On the next line «Healthy eating today:...» (describe what else you have eaten today that is healthy). Continue to fill out this sheet today and every evening for the next 10–14 days. Check and make sure that you always eat a lot of healthful foods and a wholesome breakfast!

Example:



### Healthy food, a wholesome breakfast

March 4

My breakfast today:  
1 glass milk  
Crispy muesli cereal

Healthy eating today:  
2 apples  
1 banana

March 5

My breakfast today:



## Step 3: your workplace at home

---



---

### A good workplace

You need your own workspace for your homework assignments and test preparation exercises. Ideally you have a work table for your own use in your own room. If this is not an option, it can also work this way:

Discuss with your parents where you can sit quietly for an hour every day to do your homework. It can be in the living room, the dining room or even in the kitchen. If at all possible, you should be able to sit at a real table of normal height.

**These three points are important:**

1. You must not be disturbed at your work table. Make a deal with your parents and siblings whereby they agree to not disturb you and not make any noise while you are working. You should be able to continue working in peace even though someone comes to visit.
2. You should have adequate lighting in your work space, otherwise you may ruin your eyes. Make sure that there is a good lamp nearby for that purpose.
3. If you do not have your own, fixed work place and you may work each day an hour at the kitchen or dining room table, then set-up a box to store and keep all of your work tools together. If you have your own table, then clean it up after working on it. Who would want to begin his/her work on a messy table?

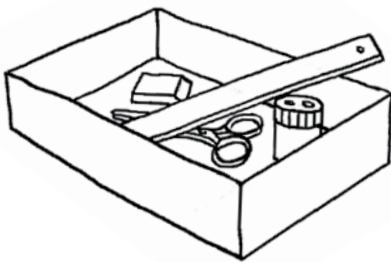

**TIP**

Discuss with your parents and siblings exactly where you can work for one hour every day without being disturbed. If you want, set up a real contract for this purpose, have it signed by everyone and hang it somewhere where it is clearly visible!

Zuerich, March 7,...

**Contract:**

**Jassin may use the dining room table for one hour every afternoon for his homework assignments.**

**Disruptions are strictly forbidden!**

Jassin \_\_\_\_\_ Mom \_\_\_\_\_

Albina \_\_\_\_\_ Dad \_\_\_\_\_  
(Sister)

**Exercise 3**



Arrange your workspace or your work box conveniently so that everything is ready for work to begin! Besides pencils, color pencils, pens, etc., also make sure you have a pencil sharpener and sufficient scrap paper! Also make sure your workspace has sufficient lighting. Add a stronger light bulb, if the place is too dark. Clean up your work space after working so that you don't have to look for displaced things the following day!

## Step 4: a quiet workplace

When you work, you must be able to concentrate. The ability to concentrate when working is essential. You will not be able to get ahead and learn anything without concentrating. Conversations, noise, television or music disrupt your concentration and distract you.



### A quiet workplace

- ▶ Make sure that your workspace is in a quiet corner of your home.
- ▶ Make an agreement with your parents and siblings so that they will not disturb you when you are studying.
- ▶ This includes turning off the tv set or radio in the room where you work as their noise would disturb your concentration and make your studying more difficult.
- ▶ If there is no other option, get earplugs or a hearing protection for the time during which you work.
- ▶ Do not play music, as it would disturb you as well. In order to concentrate and to successfully complete your assignments, you really need complete silence!

#### TIP

Make a sign that reads «Silence please!» or «Do not disturb» that you can hang on the door or in your workplace when you are studying.

#### TIP

If you like to listen to music, you can reward yourself as follows: after 15 or 20 minutes of concentrated work, you may take a short break and listen to a piece of music. Only 5 minutes, at the very most, then continue to work and concentrate in silence!

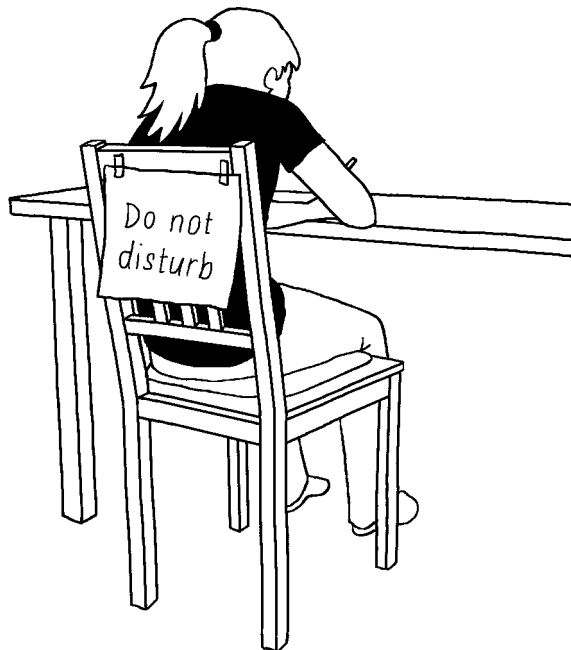

### Exercise 4

On a piece of paper, write the title «Noise and distraction protocol». Today and during the new few days, immediately write down if something disturbs or distracts you. Think about and discuss with your father and mother how these disturbances and distractions could be avoided. Write the solutions on the noise log and see if they work!

## Step 5: fixed working hours

### First work, then pleasure

Habits can make life easier for you. This also applies for regular working hours.

- ▶ Perform your assignments and test preparations at the same time every day if at all possible. Once you have acquired this habit, you don't have to think every day anew about when to sit down to do your work. This facilitates your studying and eases your burden.

#### TIP

If you are in class until lunchtime and then have the afternoon off, then begin with your hour of homework one hour after lunch. This way, you have a little bit of time to rest and relax after lunch. If you have classes in the afternoon as well, then begin your homework one half hour after returning from school. This way, you have a moment to relax and you are not yet fully submerged in leisure time.

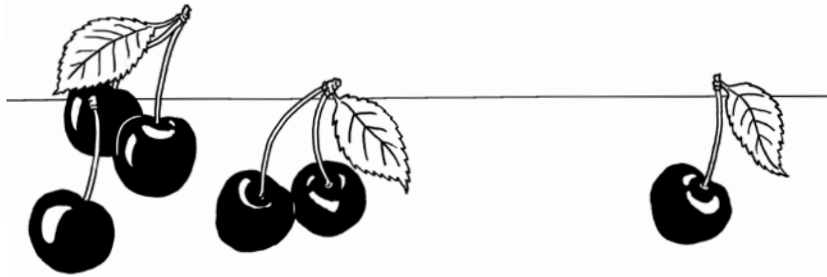

- ▶ Do not immediately begin your homework after school; rather, take a short half-hour break. Have a drink or eat a snack, talk with someone, play some music, but do not begin something time-consuming. You want to first complete your homework assignments.
- ▶ Caution: do not attempt your homework right after eating a meal. Wait at least one hour, as the body requires rest to digest.

#### TIP

In your school timetable, always enter your homework hour every day!

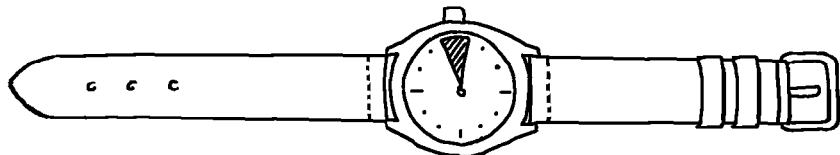

#### TIP

Make sure that you complete your assignments before all other obligations (sports, music, etc.). Follow the proverb «First work, then pleasure»!

- ▶ Reserve one hour for homework every day. If you finish earlier, so much the better. If you notice that you regularly require more time, you must reserve more time.
- ▶ If you have obligations during the afternoon or evening, e.g. a course, sports or something else, make absolutely sure that you have enough time for your assignments (preferably before the other activities!). Do not forget: the important thing for your later life and for your choice of profession is first and foremost your high school diploma!
- ▶ Complete your homework if at all possible before eating dinner. You should preferably have no more work after dinner and go to bed early.

### Exercise 5

Set your homework hour as suggested above. Record it as well in your school timetable.

In the course of the next five days, consider if this time is good for you, or if you would be more alert and concentrated at a different time of day! Make a note about it every day, for example, on the back of your distraction protocol!

## Step 6: planning the work:

### a) making a plan

Among the recipes for success of the professionals is undoubtedly that they first plan their work, and not just keep muddling along. Get accustomed to this as well! People can and must plan on various levels:

#### Monthly planning

If you already know that you have to give a presentation in three weeks or that you have a big math test coming up, it is advisable to plan the time until then. This way, you are in control of your work and will reach your objective more easily.

#### Weekly planning

Create a field for every day on your weekly plan. There you enter which assignments come due on a given day and when you have to prepare for a test or an assignment. The weekly plan provides a good overview and helps you organize your time.

#### Daily planning

With the daily plan, you plan every day what you have to do during the homework hour as well as the sequence in which you want to perform the tasks.

#### TIP

Keep an assignment booklet in school in which you carefully record what you have to complete by which day! You can also do this with an agenda, of course. Make sure it is accurate, which is the most important foundation of your work planning.

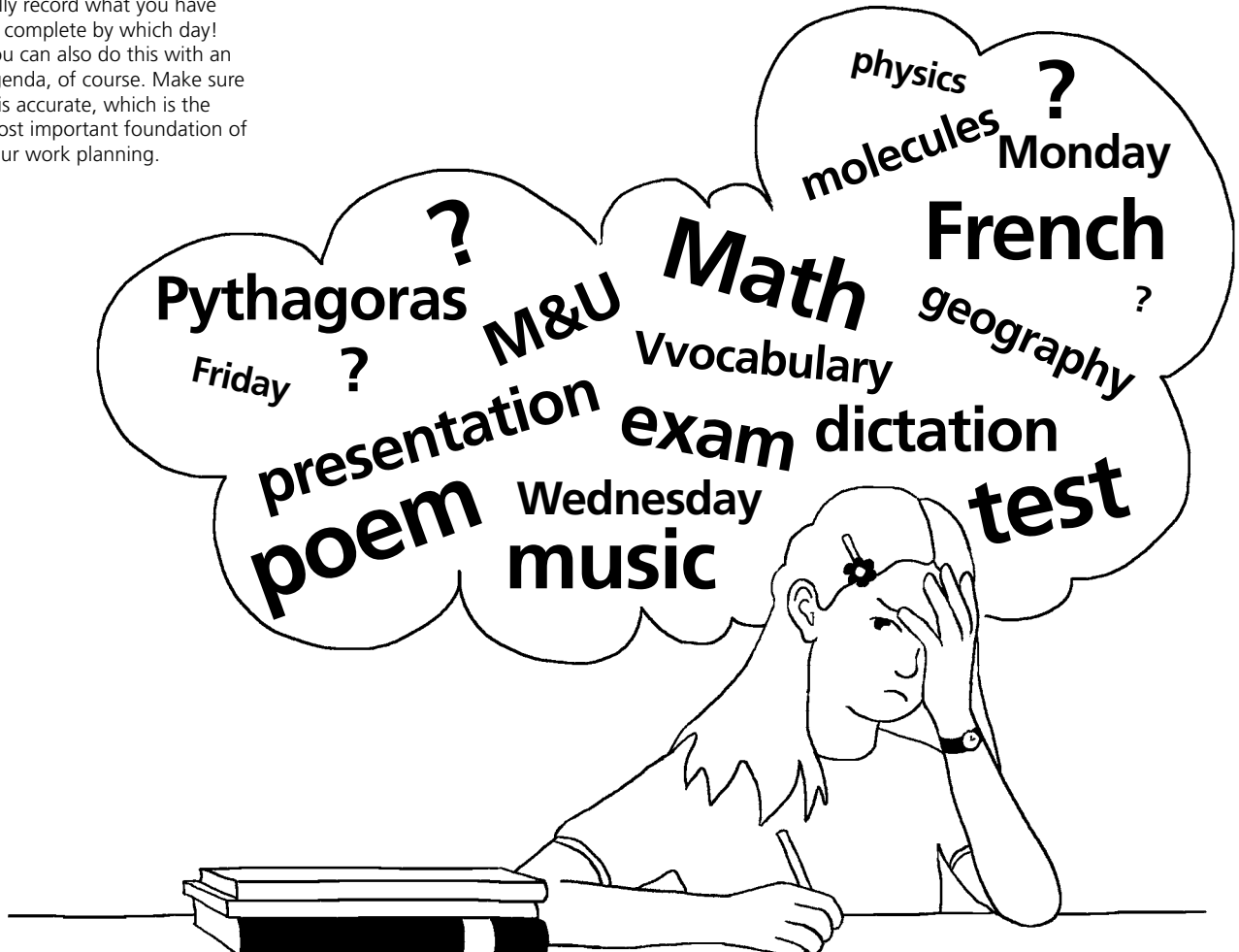



## Weekly plan: March 12 - 17

Mon	Tues	Wed	Thurs	Fri	Sat & Sun
- language book, p.117	- math book 2.44	- prepare Kangaroo presentation	- Kangaroo pres.	- English test	- Unité 17 repeat
- read + answer questions	- practice for English test	- geometry sheet A.42	- geometry A43+44	- lang. book p. 125	- geometry A.43 revise
- Unité 17 learn	- lang. sheet # 34	- math book p. 47+48	- practice for English test	- French test	
- prepare Kangaroo presentation	- math book p. 45 and work-sheet	- Unité 17 learn	- lang. book p. 123	- memorize poem	
- practice French vocab.			- memorize poem	- math A.23	
- math book p.43					

### TIP

Each week, create a weekly plan on an A4-sheet of paper. Record what you have to do for each day (assignments, preparations for tests, etc.). If you have no other assignments, you could also decide to repeat or practice something from class!

### Exercise 6

In order to familiarize yourself with the task for monthly or weekly planning, please make

1. a monthly plan in which you record all deadlines, tests, etc. which you already know. Enter also the scheduled hours for music lessons, soccer training, etc. Keep in mind, however, that you must complete your homework before.
2. one weekly plan each for this week and next week (a chart with six fields: Monday to Friday and Saturday/Sunday). Record all the assignments, etc., that you already know.

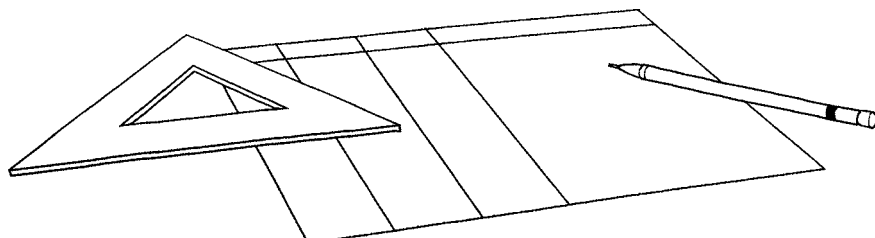
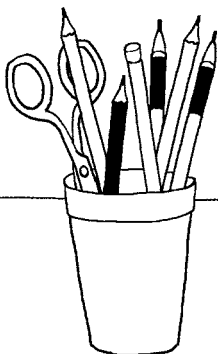

## Step7: planning the work

### b) setting goals and subgoals

If someone is planning a trip s/he must first know the destination and how many stages it will take to get there. It is exactly the same with learning; you must first have a goal and you must divide the path to this objective into subgoals, so that you can reach the objective.

Example:

- ▶ In ten days you have to give a presentation about lions. Your goal is to give a really good presentation and to obtain a good grade. You now have to divide this goal into partial goals for the next few days:

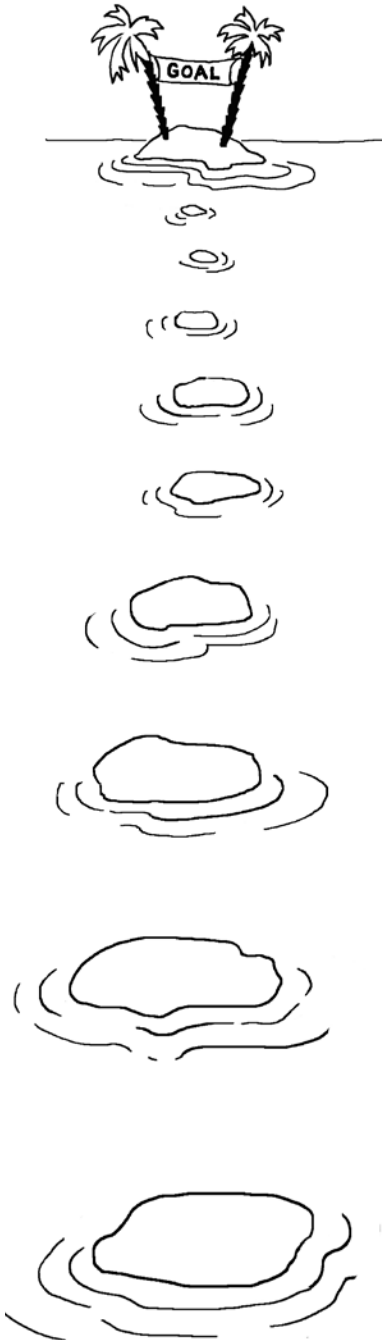

Monday	Obtain and look through books from the library about lions. Take notes.
Tuesday	Conduct an internet search. Take notes of important links.
Wednesday	Look through your notes. Create a first sketch about the structure of the presentation.
Thursday	Continue working on the sketch for the structure. Obtain missing information.
Friday	Write a first draft of the presentation.
Saturday and Sunday	Look for pictures to show with your presentation.
Monday	Re-read the presentation a few times, make necessary corrections.
Tuesday	Practice giving the presentation 2 times at home, also showing the pictures. Measure the time.
Wednesday	Practice giving the presentation by heart 2 to 3 times at home.
Thursday	Give the presentation in class!

- ▶ Consider with **every major assignment** what your **goal** is and into which **sub-goals or steps** you want to divide the path to reach this goal!
- ▶ Also, consider **every day** at the beginning of your assignment hour what your **objectives and partial objectives** are for today.

#### TIP

Each day, make a work plan at the beginning of your assignment hour in which you state the tasks to be accomplished today and the goals and sub-goals!

## Work plan for a presentation about London

<b>Week 1</b>	<b>M 3.5</b>	<b>T 3.6</b>	<b>W 3.7</b>	<b>TH 3.8</b>	<b>F 3.9</b>	<b>Sat/Sun 3.10 + 3.11</b>
	- Obtain books about London from library	- Search for info about London in the internet → take notes	- Review notes. make a sketch of the structure for presentation	- Continue working on the sketch for the structure	- Obtain missing information	- Write a first draft of the presentation

<b>Week 2</b>	<b>M 3.12</b>	<b>T 3.13</b>	<b>W 3.14</b>	<b>TH 3.15</b>	<b>F 3.16</b>	
	- Search for pictures for the topic London	- read through and review the presentation  - improve texts	- Create a quiz	- Practice the presentation 2x with presenting the pictures  → measure time	- Give presentation in school	

### TIP

With bigger assignments, also enter the partial goals that belong to this task on your weekly plan!  
The above example shows you how.

### Exercise 7

Think about which longer assignment you have to complete in the next two to three weeks. Create a plan with partial steps and partial goals (see above). If you do not have a longer assignment due at this time, imagine the following: in two weeks, you have to give a presentation about your favorite hobby. How do you proceed? Make a plan of subgoals and partial steps!



## Step 8: beginning the work

Before you begin with your work (homework assignments, preparations for exams, etc.), you should observe the following points. They will help you to begin work right away in a concentrated manner.

### 1. Work space tidied up and quiet?

Is your workspace sufficiently tidied up so that you are not distracted? Do you have writing materials, note paper, etc. at hand? Are the computer and tv turned off? If not, then address these issues first!

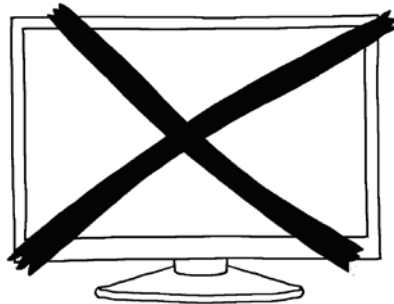

### 2. Everything ready, what do you need?

Do you have the school supplies ready which you need for your assignments? (For example, the assignment booklet, the math book, etc?) Consider first or check in the assignment booklet what you need to do and then lay out all notebooks and books that you need to complete the tasks!

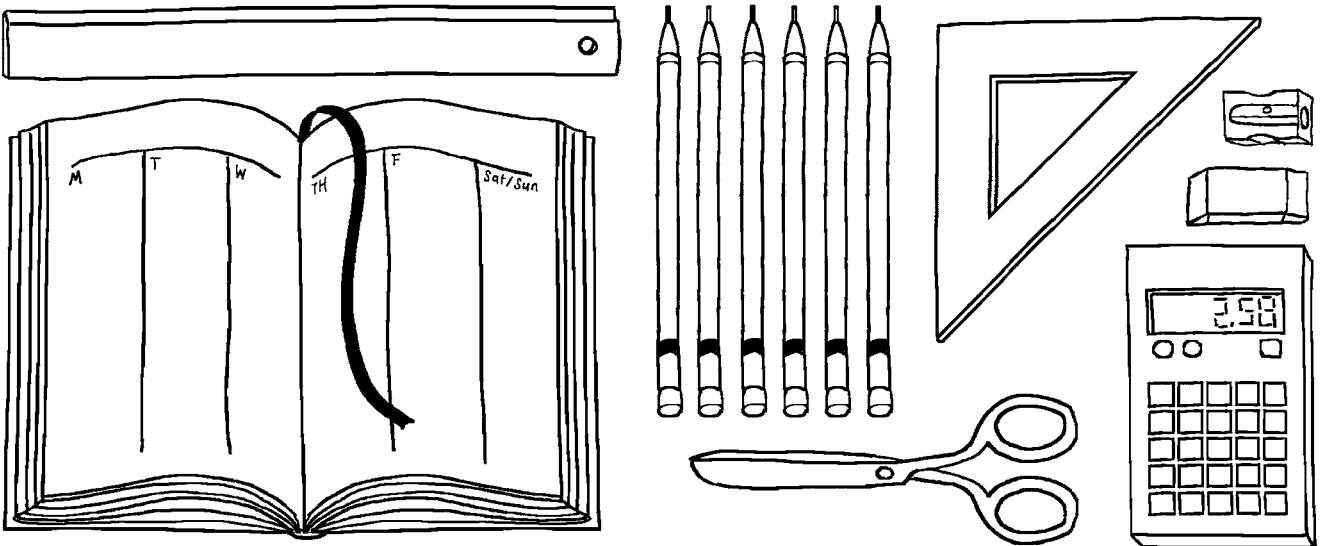

### 3. Short relaxation exercise

As an introduction to your work, first make a short relaxation exercise. For instance, you can simply stretch and yawn out loud. Or you take a DEEP breath and exhale FORCEFULLY five times. Or you cross your arms behind your head, push your ellbows back and count to five.

## 4. Creating a work plan for today

(Now apply what you learned yesterday in step 7.)

Take a note paper and write down everything you have to do today. Carefully consider the sequence. Begin with something easy or something that you like to do!

If you have an assignment that stretches over several days (e.g. preparing for a test or a presentation), then consider carefully what you have to complete today and what your partial goal is for today.

---

## 5. Let's go!

Now begin with the first task that you intended for today. Good luck!

### TIP

Affix on your table or your workbox a checklist with these five points:

1. Tidied up?
2. Everything ready?
3. Relaxation
4. Work plan
5. Let's go!

Get used to always first go through this checklist before you begin your work!

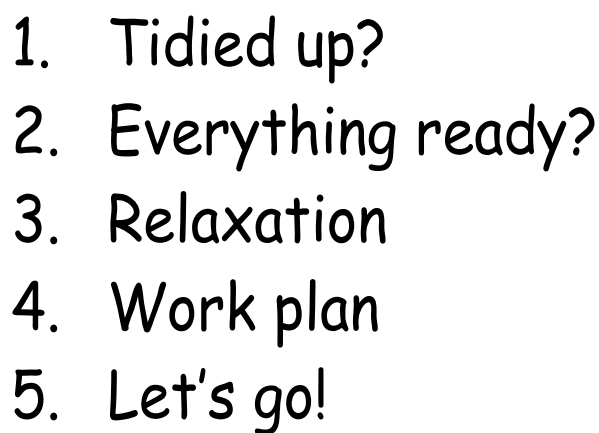
- 
1. Tidied up?
  2. Everything ready?
  3. Relaxation
  4. Work plan
  5. Let's go!

---

## Exercise 8

Today and in the next few workdays make particularly careful written workplans for your homework hour. Consider everything very carefully, including what kinds of relaxation exercises you are going to do. Begin with a simple, pleasant task. Make careful notes of everything and record at the end how you fared today with your work.

## Step 9: working in a concentrated manner, taking breaks

---

Only when you work in a concentrated manner can you learn. If you sit at your table, unfocused and your thoughts are elsewhere, you only waste your time, and then you must do your work later!

In order to help you concentrate, here are a few tips:

---

### **Looking forward to work and have your work under control**

The work plan which you establish each day will help you for this purpose. If you consider carefully what you have to do today and have it arranged in sequence, everything becomes much more manageable. Remember: begin with something easy or with something that is fun!

---

### **No distractions**

Things that can distract you, for example, are an untidy workspace, noise, music, television or other people. See step 3 and 4!

---

### **Take a break every 15–20 minutes**

Take a break every 15–20 minutes, if at all possible between two assignments, of 2–5 minutes (not longer!). During this break you can, for example, stand up, stretch, open the window to get some fresh air or drink some water.

If you have to work for more than an hour, then take a break of 10–15 minutes after an hour. Drink something, move about, or listen to a piece of music!

---

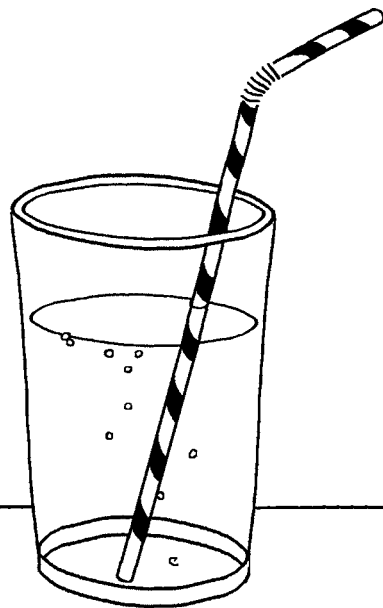

## Short concentration and relaxation exercises

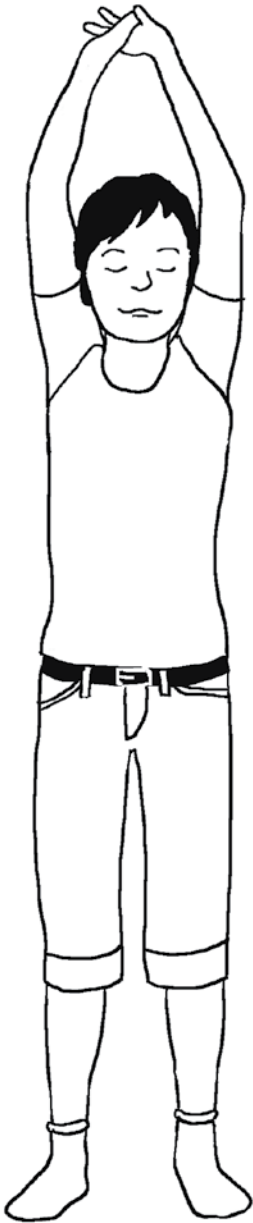

- Close your eyes for a minute and concentrate only on your breathing.

- Inhale DEEPLY and exhale FORCEFULLY five times!

- Try to concentrate for two minutes entirely on the second hand of your watch. Wipe away immediately any other thought.

- With your finger, draw a figure eight on the table and keep drawing it for a minute.

- With your fingertips, massage your head (forehead, temples, hairline).

- Expand and stretch; continue with relaxation exercise #3 from step 8!

### Variety in what you learn

Try out all the relaxation and concentration exercises today. Consider which ones are most helpful when you want to relax and then concentrate well! You can also expand the list with additional exercises.

---

### Exercise 9

Try out all the relaxation and concentration exercises today. Consider which ones are most helpful when you want to relax and then concentrate well! You can also expand the list with additional exercises.

# S10 Step 10: and if once you absolutely don't feel like....

---

Sometimes you feel like doing anything but learning. And yet, the homework must get done! In conclusion, we offer you a few tips how you can improve your motivation again. Good luck!



- ▶ Look again at your work plan for today (see steps 6 and 8 above). Did you craft this work plan carefully? Does it begin with something that you do well and like to do? Did you divide larger tasks into partial goals that you can manage more easily?
- ▶ Think about the reason for your reluctance. Are you sad, do you have a problem? Are you afraid of something related to school? Do you feel like you won't be able to succeed? Maybe you should speak about your feelings with someone who understands you. Or, you should encourage yourself by formulating positive thoughts, like «I can do this!», «I am going to make a new attempt and I will succeed!». However, if you don't feel at all like working at this moment, then either give yourself a push, or consider, by way of an exception, to postpone your homework hour for later!
- ▶ However, if you regularly feel tired and listless during your work hour, then consider scheduling it during another time. Every person has more active or passive times in their daily routine (most people are active between 4–6pm or 7pm). Consider if this would not be a better timeslot for you.
- ▶ You can also motivate yourself in seeking out a role model. This can be a famous personality (Albert Einstein, mother Teresa, ...) or it can be someone from your class or an acquaintance who impresses you. To emulate this role model would be great! However, it won't happen entirely without work – so let's get going!



- ▶ It is a good idea to keep a diary or a daily journal for learning. In this booklet you record at the end of every homework hour how you fared with learning and how you feel now. Review this diary every two to three weeks and consider if you can learn something about your own life and maybe improve some things.
- ▶ A learning poster is a very useful tool, and will help you keeping oversight, particularly with larger topics. Join together four A4-sheets and write in the center the name of your theme (e. g. «the Romans»). Around them, draw circles or squares as sub-areas about which you need to learn something (clothing, history, usw.). Circle in yellow the areas with which you have already dealt with. You will see your progress as more and more circles turn yellow. See also the learning technique T4 «creating a learning poster».

Example:

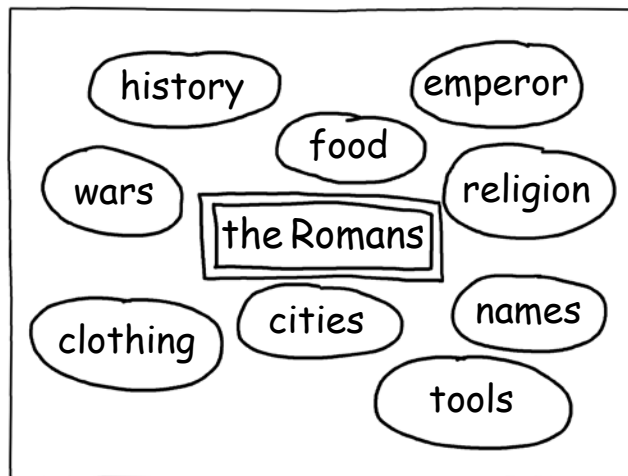

**Congratulations!**  
**Your training program**  
**is now (almost) finished.**



Bravo, if you have worked through the training program up to this point! You have learned a lot and will continue to do many things like the learning professionals do. We wish you much luck and successful learning!

If you have not (yet) thoroughly worked through everything, then simply do it now. You will see: it is worth the effort!

At the very end, here is one more exercise. It will help you to think through everything and consider what you still could improve upon.

**Exercise 10:**  
**the final exercise!**

Following your proud conclusion of the training program, we want to look back one more time. With many steps (1, 2, 4, 5 and 8) you have taken notes. Read through them one more time. Think of all the days of this training program and leaf through the pertinent pages one more time.

Consider the following and make a few notes about it:

- What have you learned in this training program, what can you do better now than before?
- What did not go so well, what do you still have to improve?
- How could you improve the things that did not go so well? Make a proposal!

The series “Materials for heritage language teaching” is comprised of six volumes, designed to enhance the quality of heritage language teaching (HSU, in Switzerland: HSK) and to improve its cross-linking with regular classroom education.

The publications address the specific needs of future and current heritage language teachers as well as their support institutions in the countries of origin and in the immigration countries. The foundation text (Handbook and workbook: Foundations and backgrounds) includes, among other things, key aspects of current pedagogy, didactics and methodology in the Western and North European countries.

The workbooks provide teaching suggestions and offer specific prompts and planning models for various instructional areas (promotion of writing in the heritage language, etc.). The publications were created in close collaboration with practicing HSU instructors in order to ensure the practical relevance and application of the didactic suggestions from the beginning.

The series includes the following publications:



The publications “Materials for heritage language teaching” have been released in German, English, Albanian, Bosnian/Croatian/Serbian, Portuguese and Turkish. They are published by the Center for International Projects in Education (IPE) of the Zurich University of Teacher Education.